

Time Period: 07:45-08:45
 Assessment Year: 2008
 Scenario: Background Demand

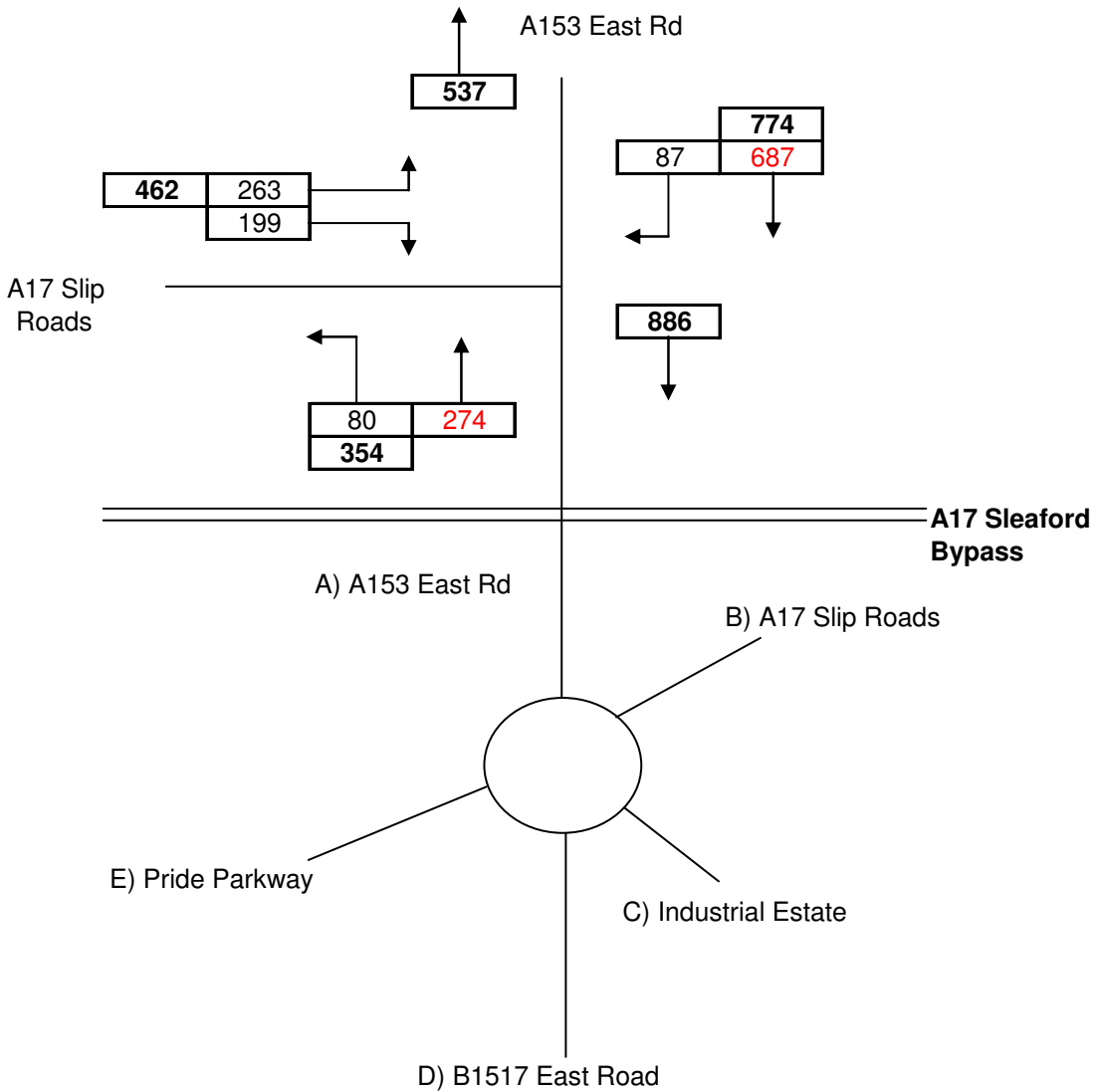

	A	B	C	D	E	Total
A		288	24	536	38	886
B	87		8	136	26	257
C	2	1		3	0	6
D	243	61	3		49	356
E	22	21	1	16		60
Total	354	371	36	691	113	1565

Figure 3a

Observed March 2008 Traffic Flow Demand at Bone Mills Junctions
 AM Peak Period



Camellia House
 76 Water Lane,
 Wilmslow
 Cheshire, SK9 5BB

Eco 2

Sleaford RRP

March 2008

APB

552-01

Time Period: 12:00-13:00
 Assessment Year: 2008
 Scenario: Background Demand

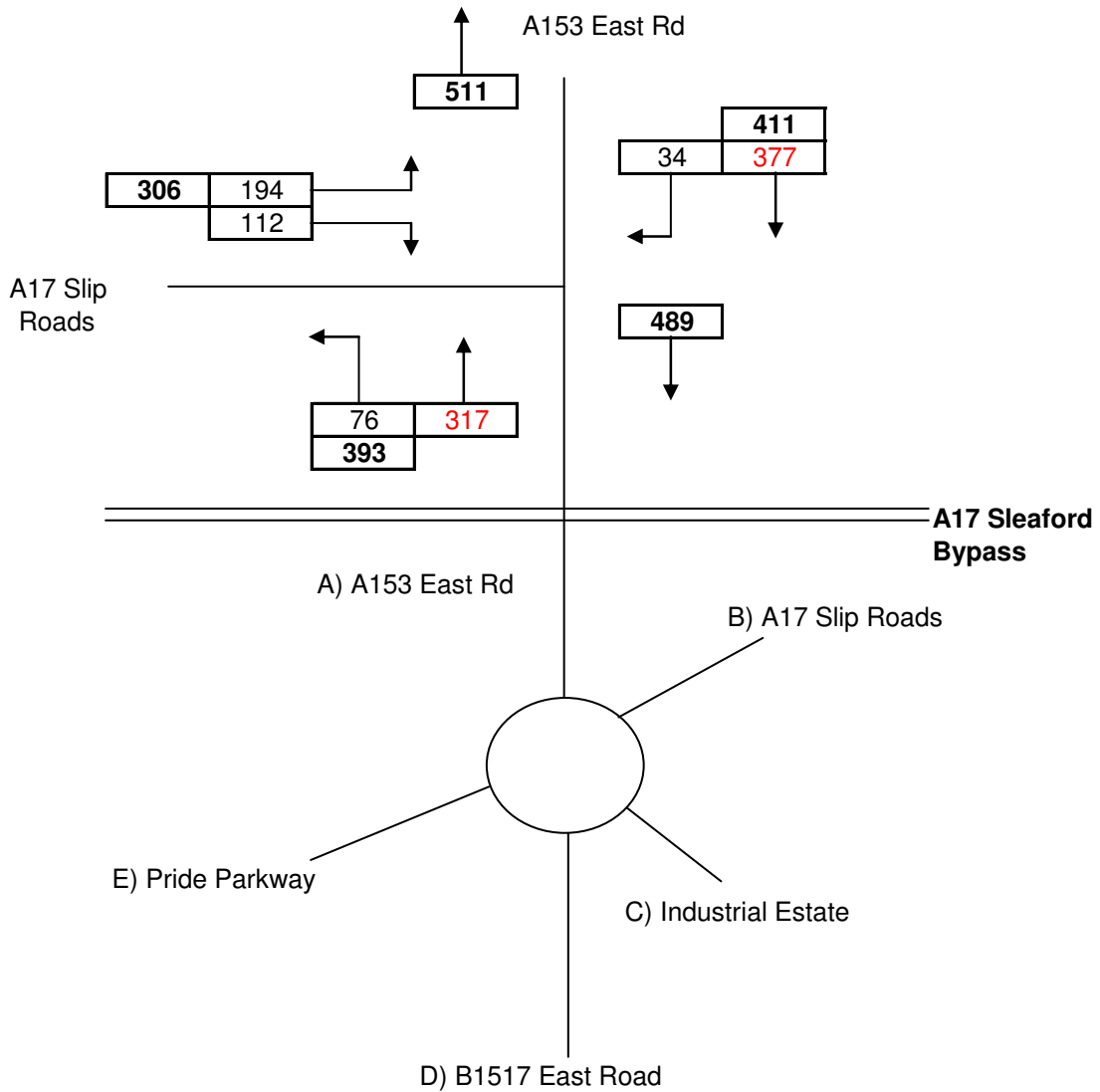

	A	B	C	D	E	Total
A		174	9	274	32	489
B	50		3	49	14	116
C	6	6		10	0	22
D	311	101	4		34	450
E	26	31	1	31		89
Total	393	312	17	364	80	1166

Figure 3b

Observed March 2008 Traffic Flow Demand at Bone Mills Junctions
 Lunchtime Peak Period



Camellia House
 76 Water Lane,
 Wilmslow
 Cheshire, SK9 5BB

Eco 2

Sleaford RRP

March 2008

APB

552-01

Time Period: 16:15-17:15
 Assessment Year: 2008
 Scenario: Background Demand

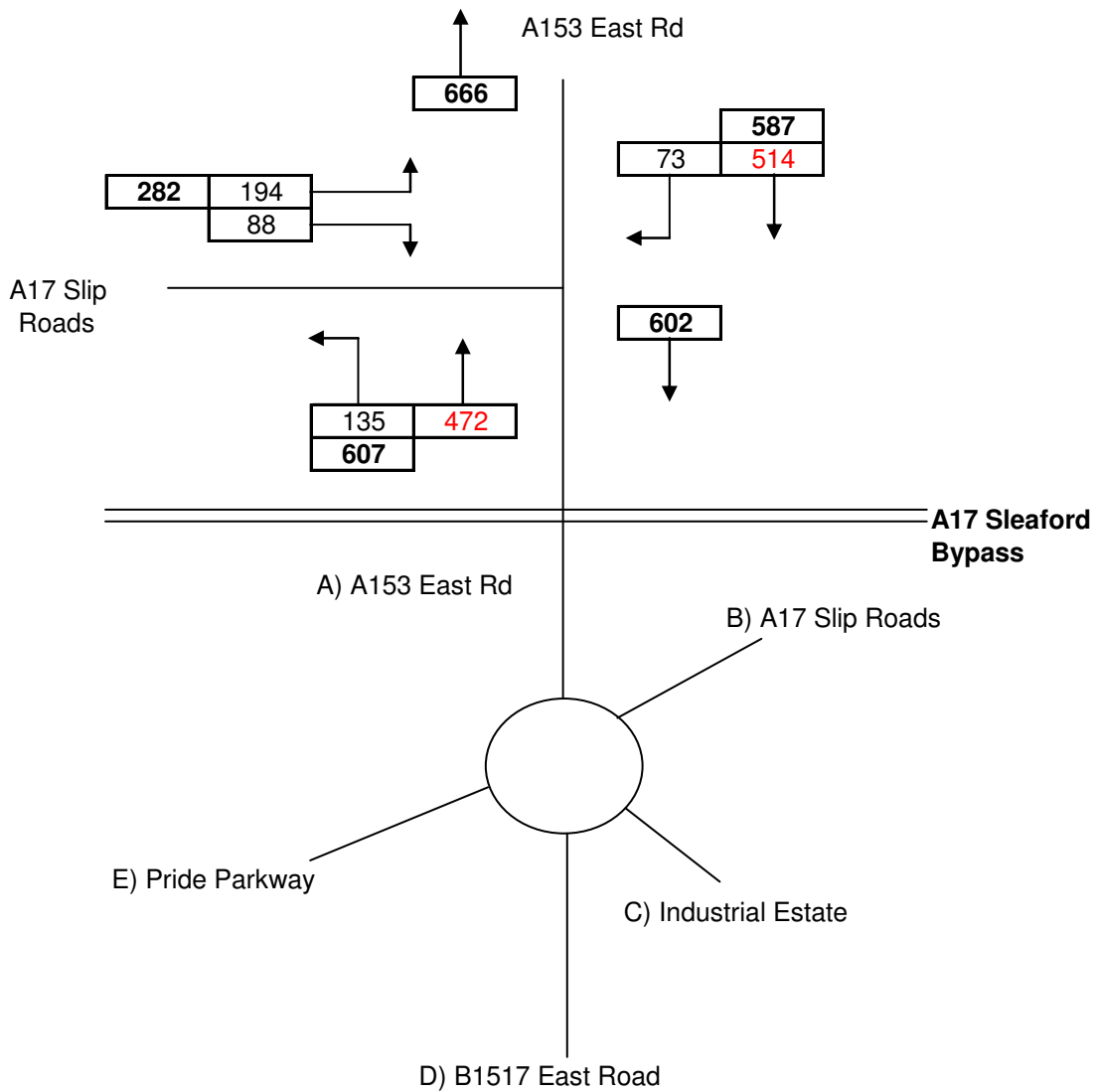

	A	B	C	D	E	Total
A		323	6	242	31	602
B	93		3	43	14	153
C	10	10		5	1	26
D	453	168	0		23	644
E	51	49	1	27		128
Total	607	550	10	317	69	1553

Figure 3c

Observed March 2008 Traffic Flow Demand at Bone Mills Junctions
 PM Peak Period



Camellia House
 76 Water Lane,
 Wilmslow
 Cheshire, SK9 5BB

Eco 2

Sleaford RRP

March 2008

APB

552-01

Time Period: Daily Demand
 Assessment Year:
 Scenario: Sleaford REP Demand (A153 Traffic) - TYPICAL DEMAND

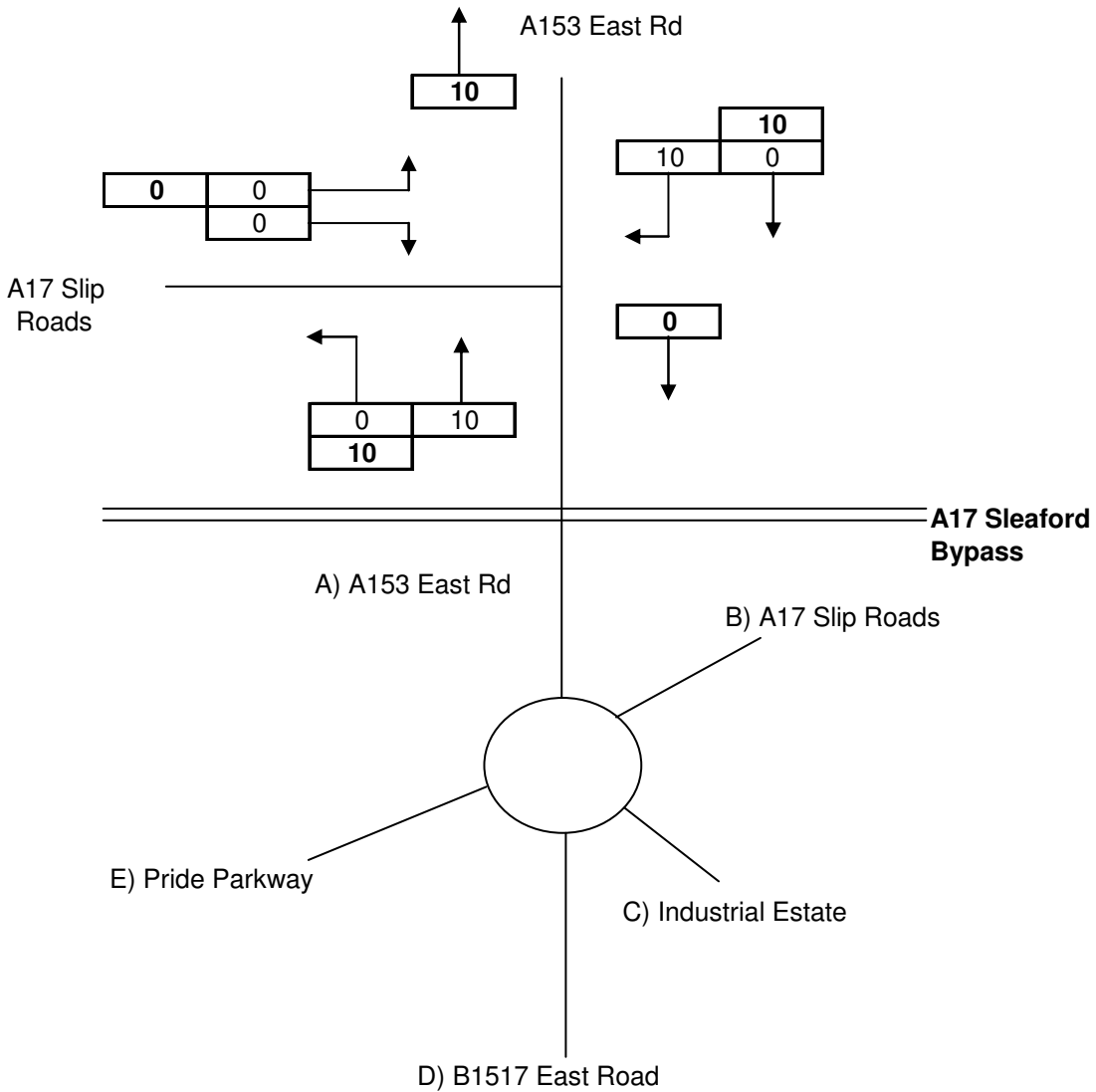

	A	B	C	D	E	Total
A		0				0
B	10					10
C						0
D						0
E						0
Total	10	0	0	0	0	10

Figure 5a

Predicted daily Sleaford REP development traffic demand on A153 corridor at Bone Mills Interchange – TYPICAL DEMAND SCENARIO



Camellia House
 76 Water Lane,
 Wilmslow
 Cheshire, SK9 5BB

Eco 2

Sleaford RRP

March 2008

APB

552-01

Time Period: Daily Demand
 Assessment Year:
 Scenario: Sleaford REP Demand (A153 Traffic) - SENSITIVITY DEMAND

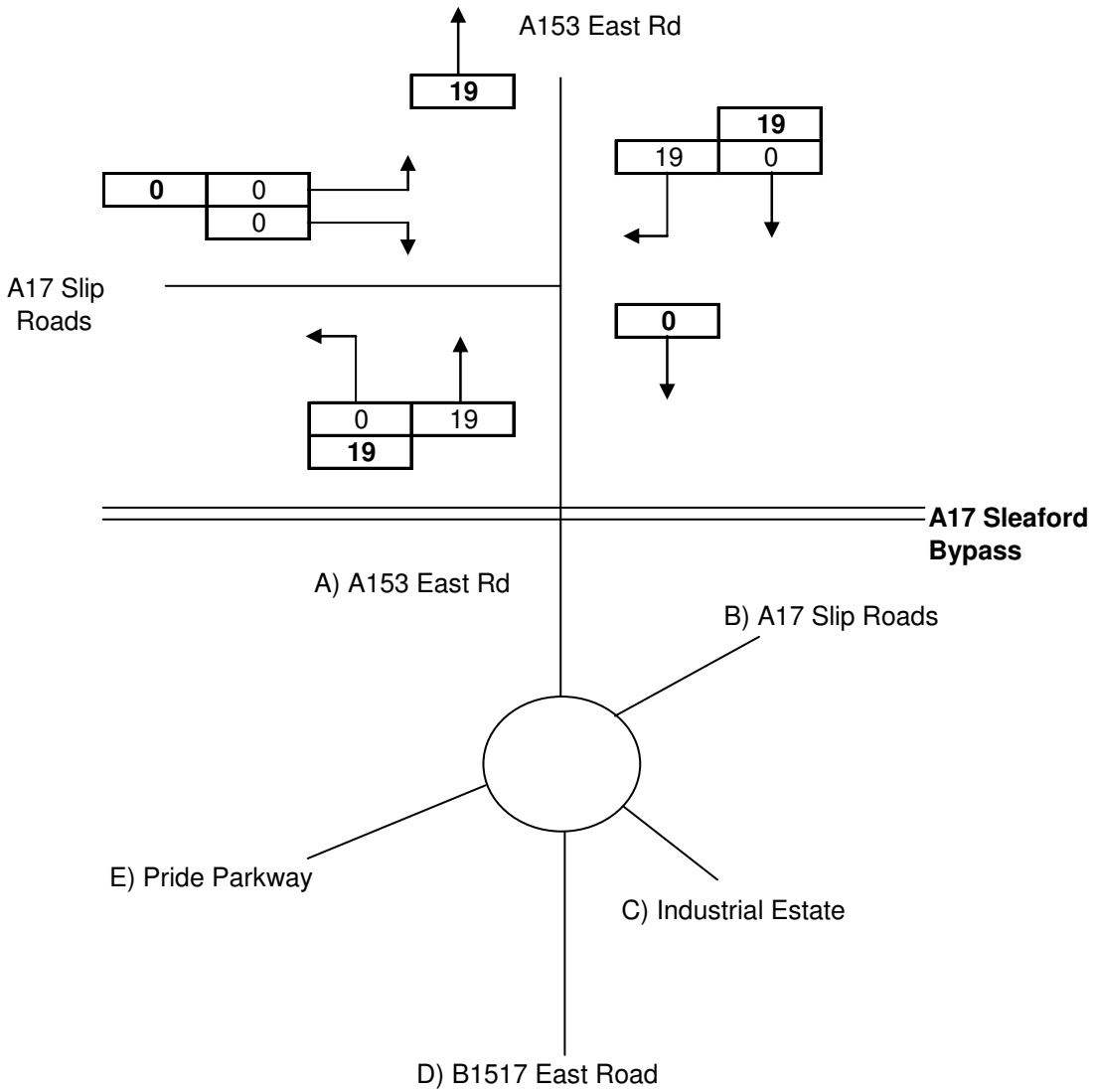

	A	B	C	D	E	Total
A						0
B	19					19
C						0
D						0
E						0
Total	19	0	0	0	0	19

Figure 5b

Predicted daily Sleaford REP development traffic demand on A153 corridor at Bone Mills Interchange – SENSITIVITY DEMAND SCENARIO



Camellia House
 76 Water Lane,
 Wilmslow
 Cheshire, SK9 5BB

Eco 2

Sleaford RRP

March 2008

APB

552-01

Time Period: Daily Demand
 Assessment Year:
 Scenario: Sleaford REP Demand (A17 U-turn traffic) - TYPICAL DEMAND

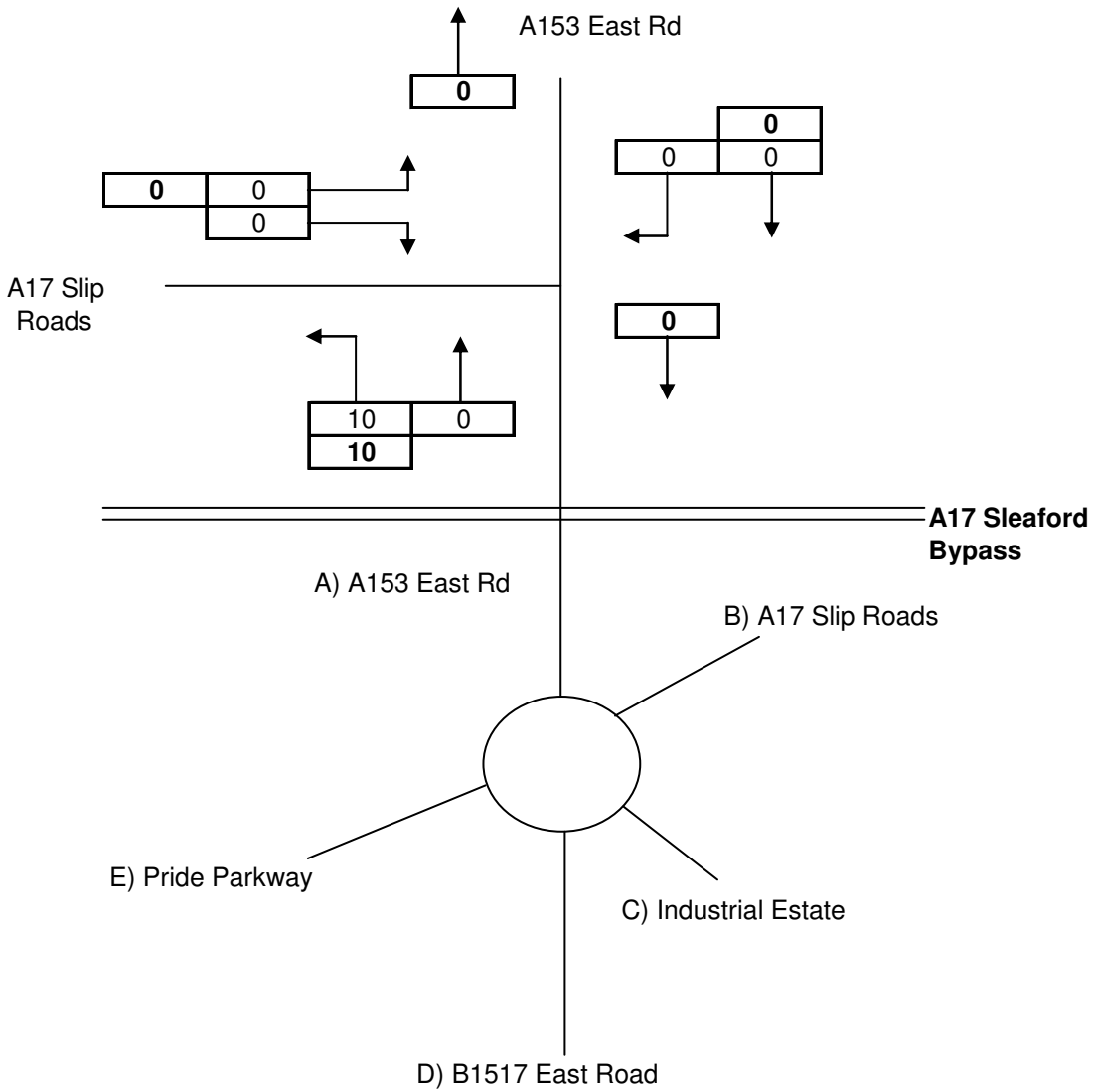

	A	B	C	D	E	Total
A						0
B	10					10
C						0
D						0
E						0
Total	10	0	0	0	0	10

Figure 6a

Predicted daily Sleaford REP development traffic demand for proposed A17(E) U-turn at Bone Mills Interchange – TYPICAL DEMAND SCENARIO



Camellia House
 76 Water Lane,
 Wilmslow
 Cheshire, SK9 5BB

Eco 2

Sleaford RRP

March 2008

APB

552-01

Time Period: Daily Demand
 Assessment Year:
 Scenario: Sleaford REP Demand (A17 U-turn traffic) - SENSITIVITY DEMAND

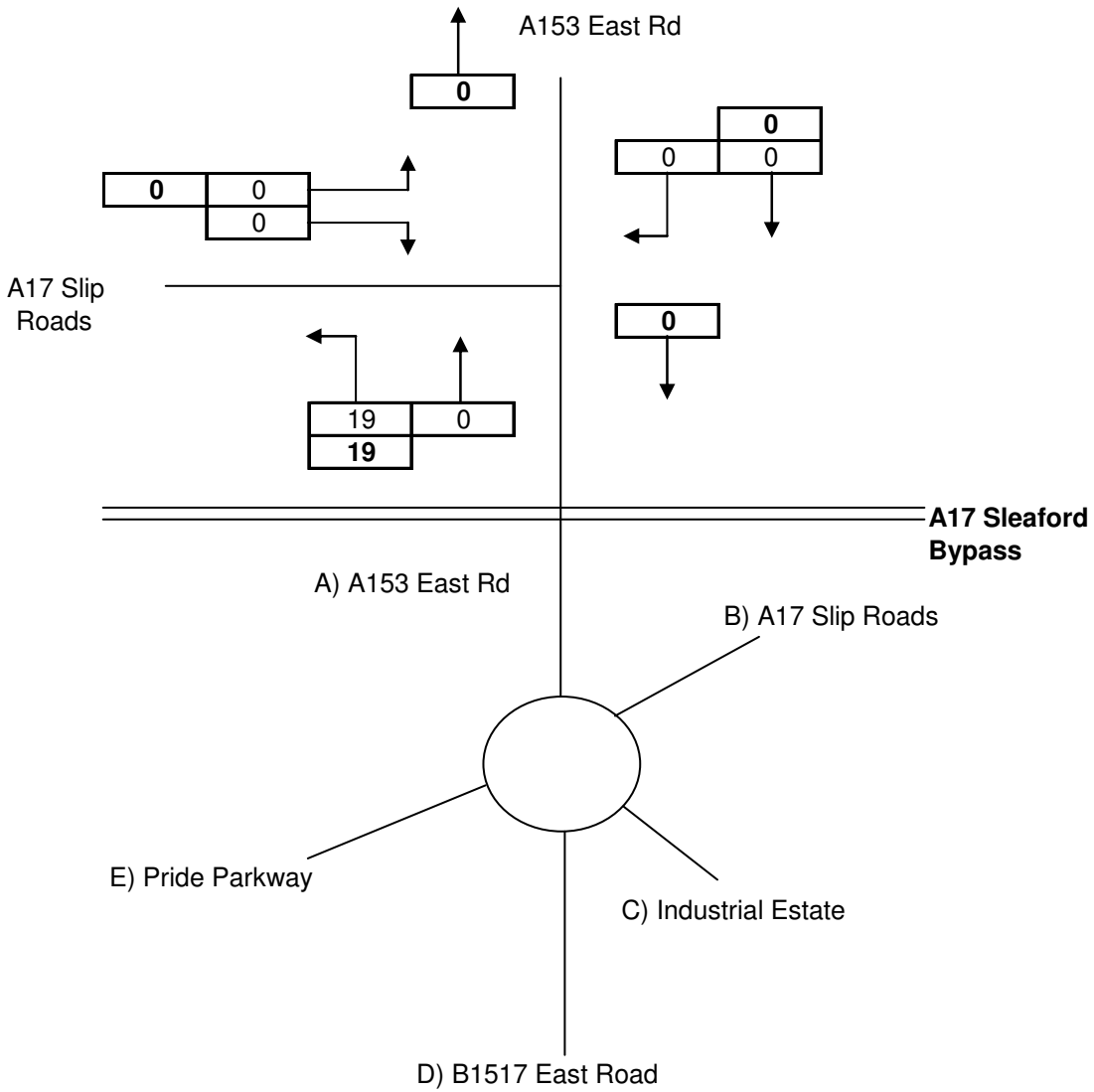

	A	B	C	D	E	Total
A						0
B	19					19
C						0
D						0
E						0
Total	19	0	0	0	0	19

Figure 6b

Predicted daily Sleaford REP development traffic demand for proposed A17(E) U-turn at Bone Mills Interchange – SENSITIVITY DEMAND SCENARIO



Camellia House
 76 Water Lane,
 Wilmslow
 Cheshire, SK9 5BB

Eco 2

Sleaford RRP

March 2008

APB

552-01

Time Period: Daily Demand
 Assessment Year:
 Scenario: Total Sleaford REP Demand - TYPICAL DEMAND

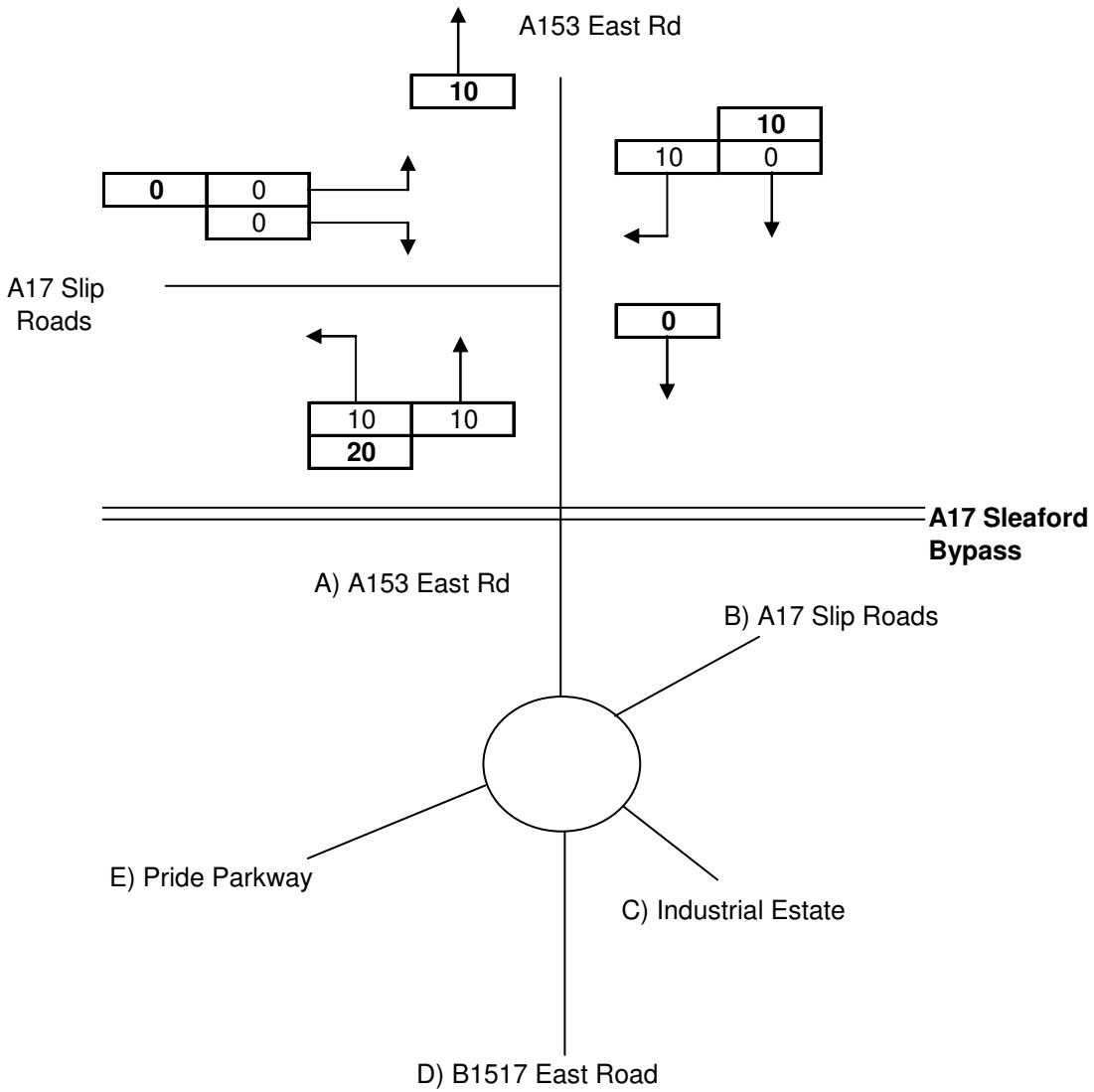

	A	B	C	D	E	Total
A		0				0
B	20					20
C						0
D						0
E						0
Total	20	0	0	0	0	20

Figure 7a

Total daily Sleaford REP development traffic demand at Bone Mills Interchange – TYPICAL DEMAND SCENARIO



Camellia House
 76 Water Lane,
 Wilmslow
 Cheshire, SK9 5BB

Eco 2

Sleaford RRP

March 2008

APB

552-01

Time Period: Daily Demand
 Assessment Year:
 Scenario: Total Sleaford REP Demand - SENSITIVITY DEMAND

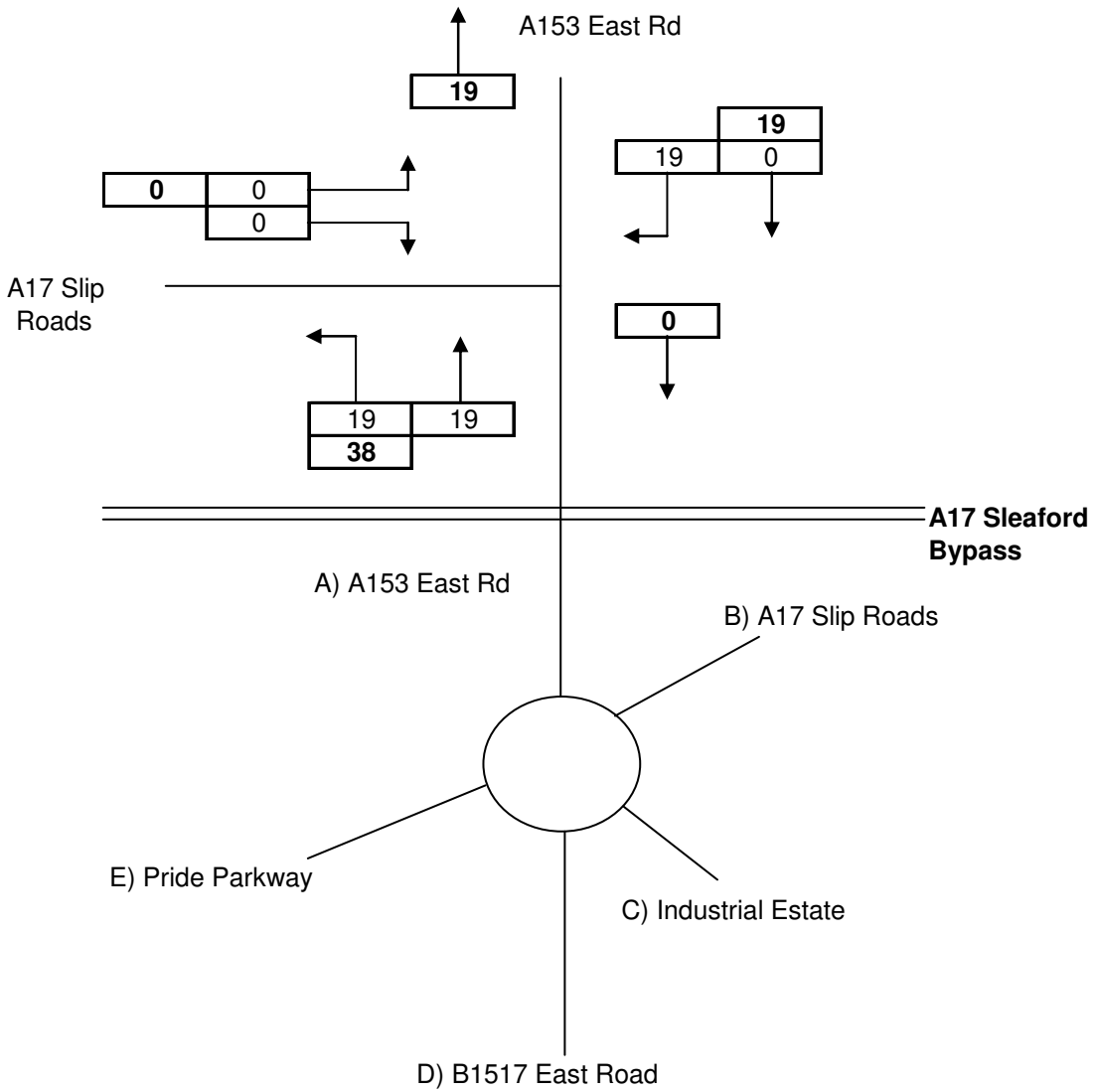

	A	B	C	D	E	Total
A		0				0
B	38					38
C						0
D						0
E						0
Total	38	0	0	0	0	38

Figure 7b

Total daily Sleaford REP development traffic demand at Bone Mills Interchange – SENSITIVITY DEMAND SCENARIO



Camellia House
 76 Water Lane,
 Wilmslow
 Cheshire, SK9 5BB

Eco 2

Sleaford RRP

March 2008

APB

552-01

Time Period: Hourly Demand
 Assessment Year: Total Sleaford REP Demand - TYPICAL DEMAND
 Scenario:

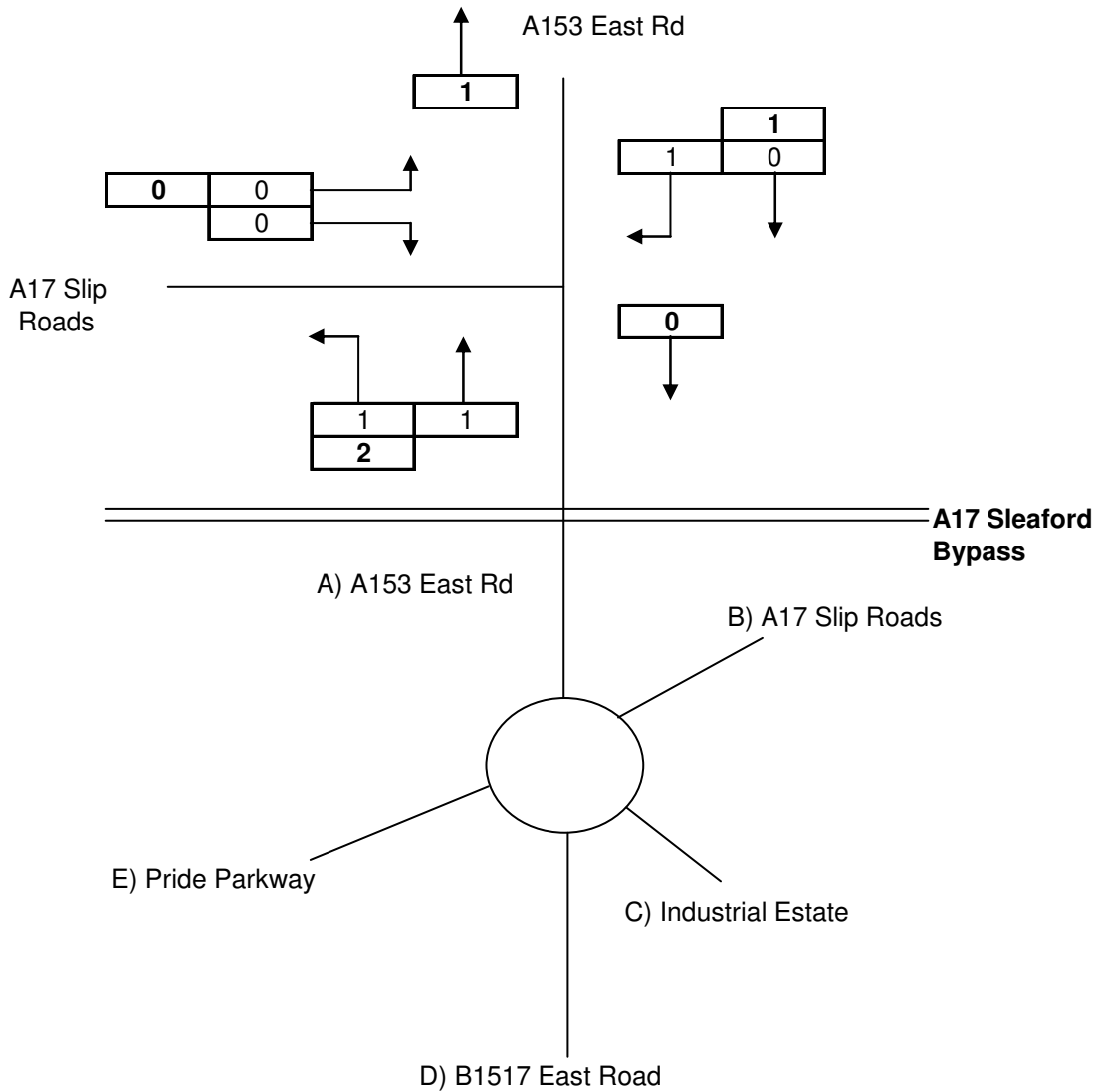

	A	B	C	D	E	Total
A		0				0
B	2					2
C						0
D						0
E						0
Total	2	0	0	0	0	2

Figure 8a

Total hourly Sleaford REP development traffic demand at Bone Mills Interchange – TYPICAL DEMAND SCENARIO



Camellia House
 76 Water Lane,
 Wilmslow
 Cheshire, SK9 5BB

Eco 2

Sleaford RRP

March 2008

APB

552-01

Time Period: Hourly Demand
 Assessment Year:
 Scenario: Total Sleaford REP Demand - SENSITIVITY DEMAND

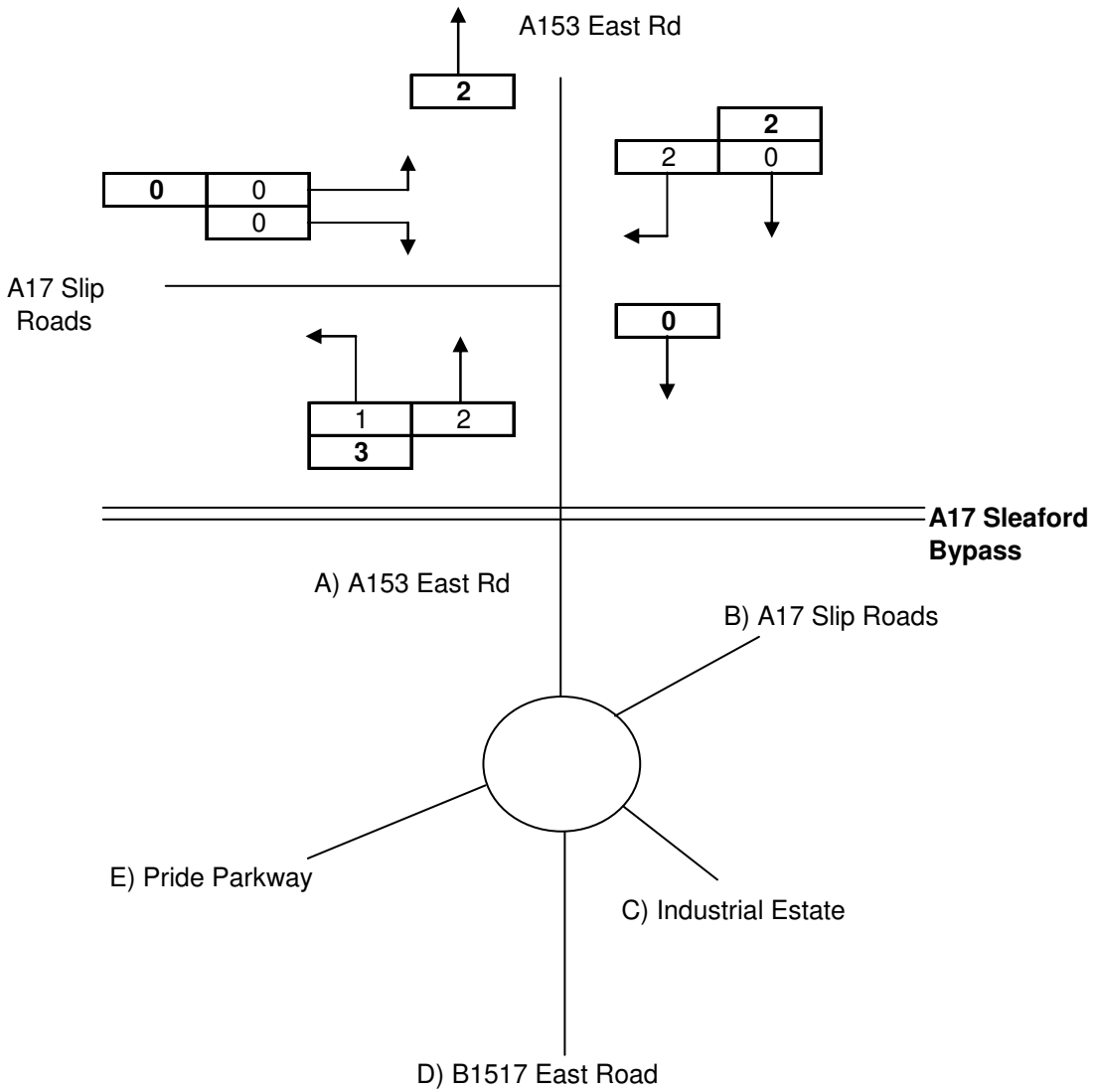

	A	B	C	D	E	Total
A						0
B	3					3
C						0
D						0
E						0
Total	3	0	0	0	0	3

Figure 8b

Total hourly Sleaford REP development traffic demand at Bone Mills Interchange – SENSITIVITY DEMAND SCENARIO



Camellia House
 76 Water Lane,
 Wilmslow
 Cheshire, SK9 5BB

Eco 2

Sleaford RRP

March 2008

APB

552-01

Time Period: 07:45-08:45
 Assessment Year: 2012
 Scenario: Background Demand

2008-2012 Factor
1.07

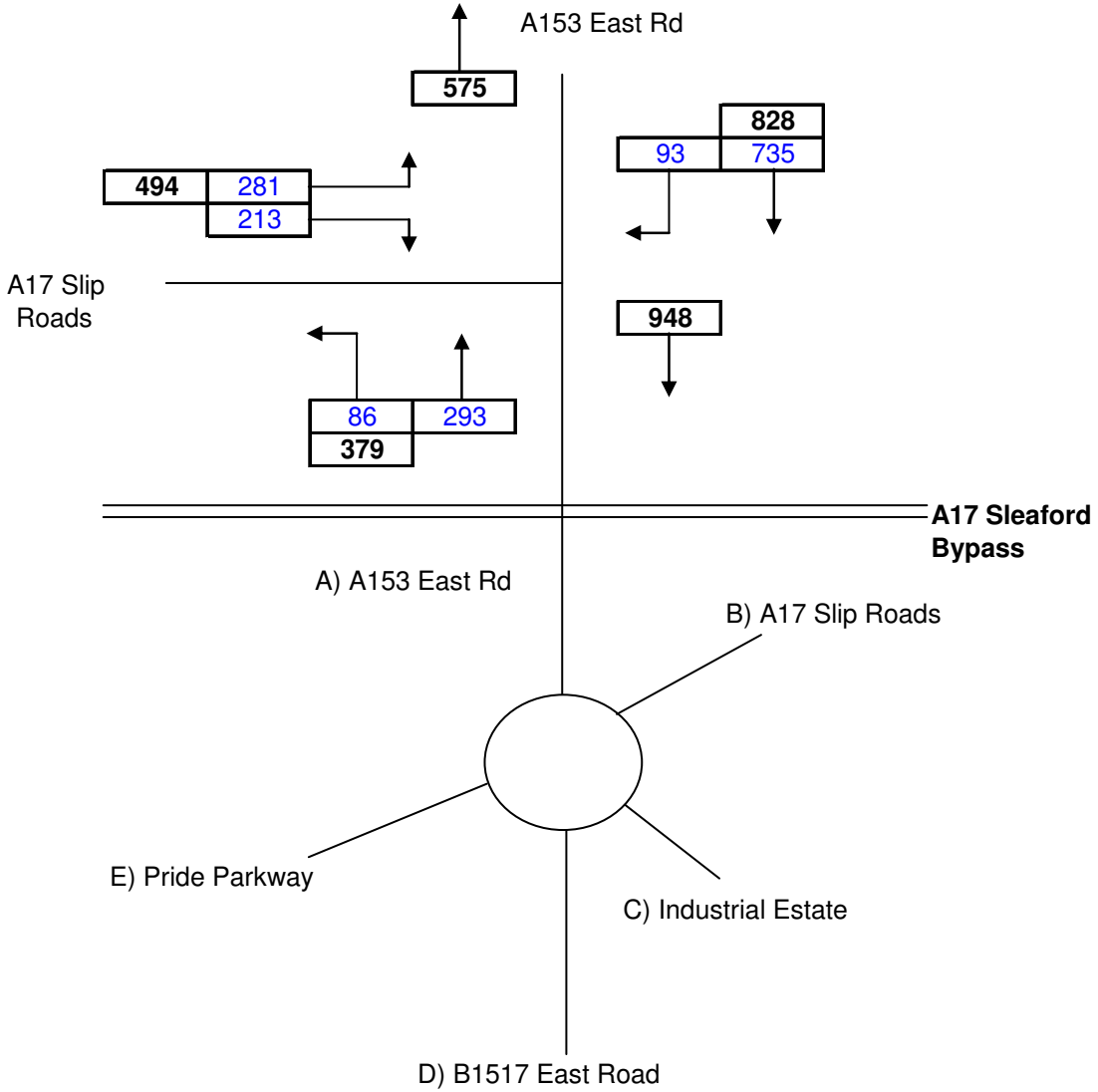

	A	B	C	D	E	Total
A		308	26	574	41	948
B	93		9	146	28	275
C	2	1		3	0	6
D	260	65	3		52	381
E	24	22	1	17		64
Total	379	397	39	739	121	1675

Figure 9a

Predicted 2012 Opening Year Traffic Flow Demand at Bone Mills Junctions
 AM Peak Period



Camellia House
 76 Water Lane,
 Wilmslow
 Cheshire, SK9 5BB

Eco 2

Sleaford RRP

March 2008

APB

552-01

Time Period: 12:00-13:00
 Assessment Year: 2012
 Scenario: Background Demand

2008-2012 Factor
1.07

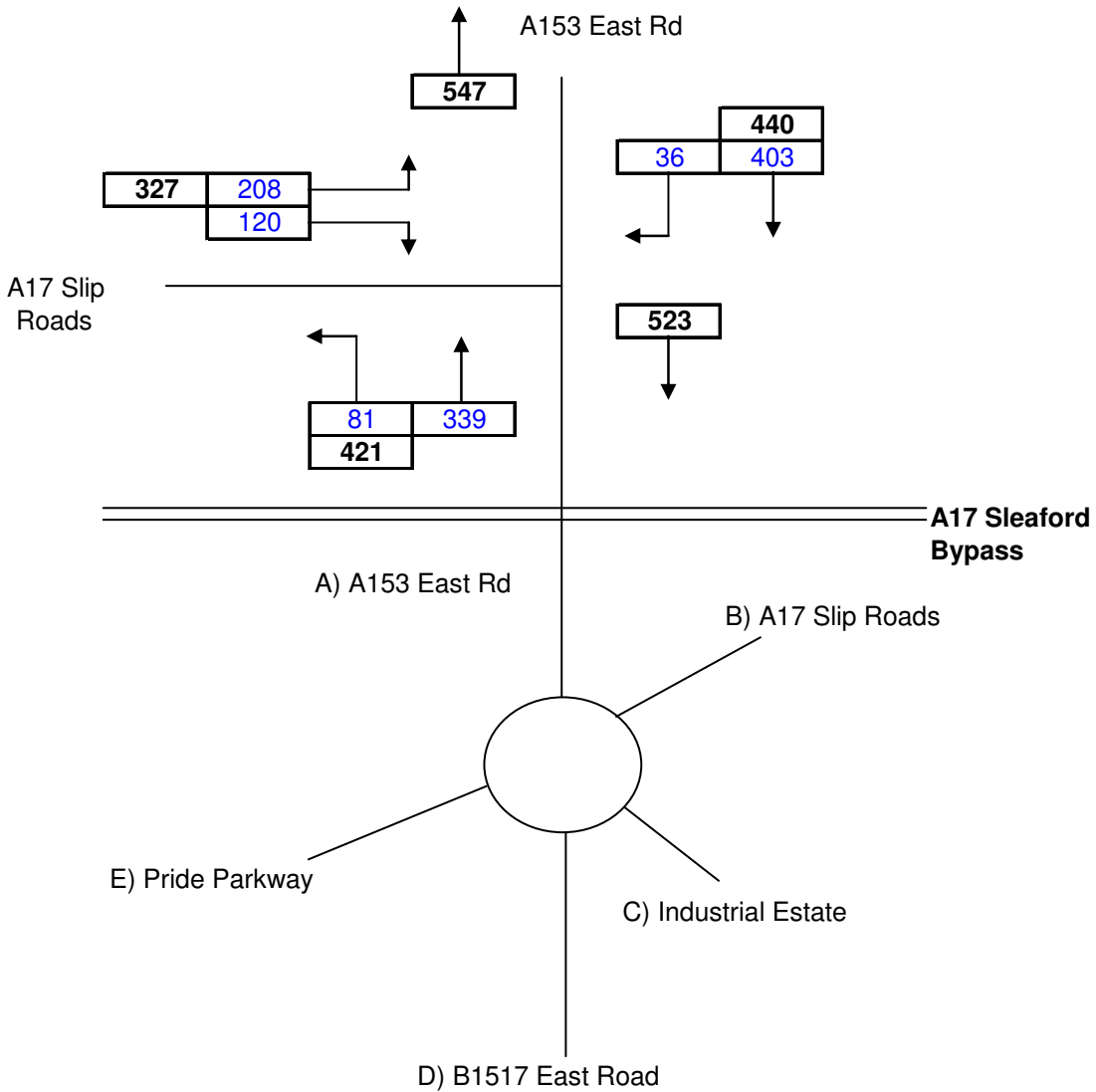

	A	B	C	D	E	Total
A		186	10	293	34	523
B	54		3	52	15	124
C	6	6		11	0	24
D	333	108	4		36	482
E	28	33	1	33		95
Total	421	334	18	389	86	1248

Figure 9b

Predicted 2012 Opening Year Traffic Flow Demand at Bone Mills Junctions
 Lunchtime Peak Period



Camellia House
 76 Water Lane,
 Wilmslow
 Cheshire, SK9 5BB

Eco 2

Sleaford RRP

March 2008

APB

552-01

Time Period: 16:15-17:15
 Assessment Year: 2012
 Scenario: Background Demand

2008-2012 Factor
1.07

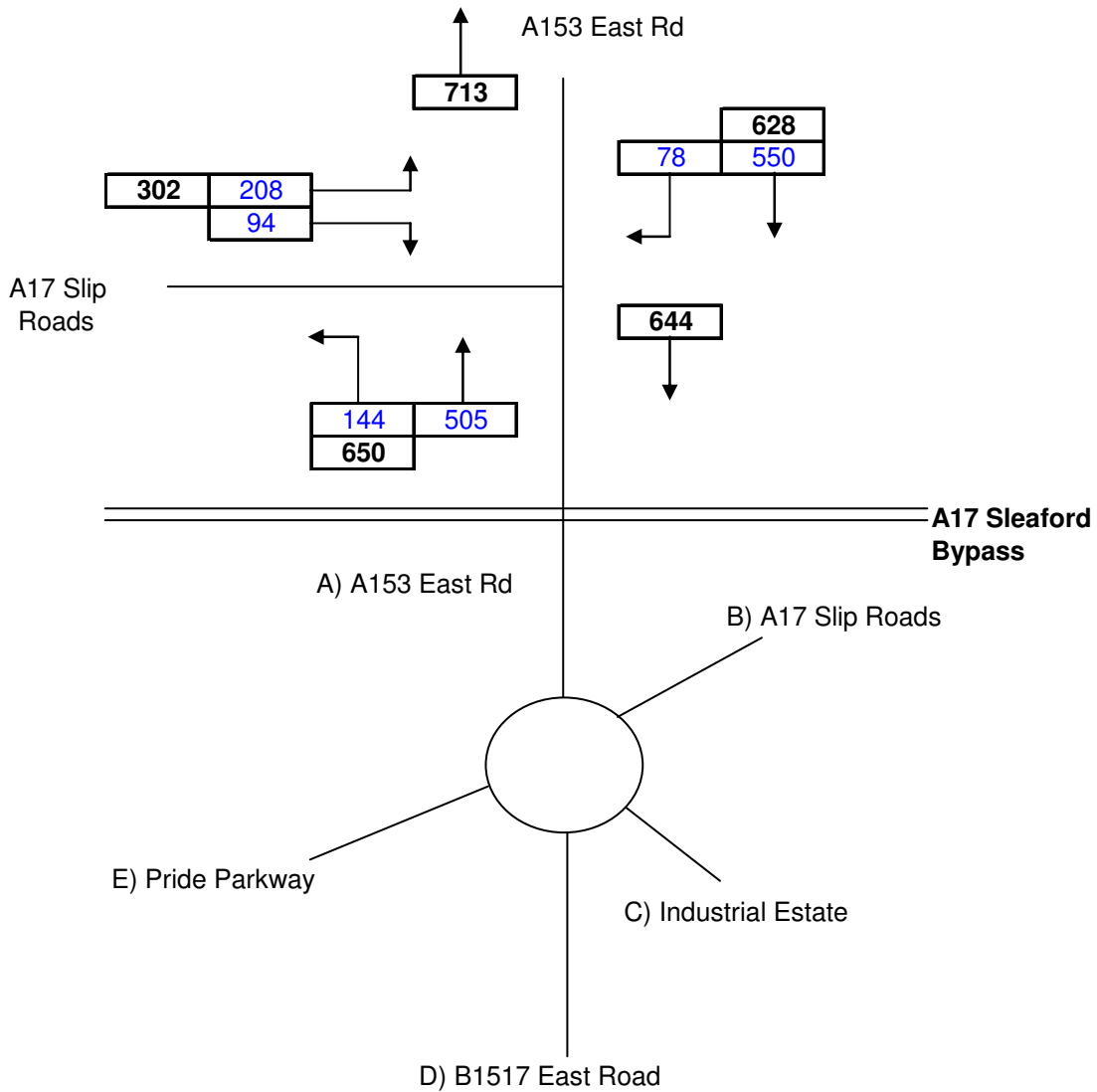

	A	B	C	D	E	Total
A		346	6	259	33	644
B	100		3	46	15	164
C	11	11		5	1	28
D	485	180	0		25	689
E	55	52	1	29		137
Total	650	589	11	339	74	1662

Figure 9c

Predicted 2012 Opening Year Traffic Flow Demand at Bone Mills Junctions
 PM Peak Period



Camellia House
 76 Water Lane,
 Wilmslow
 Cheshire, SK9 5BB

Eco 2

Sleaford RRP

March 2008

APB

552-01

Time Period: 07:45-08:45
 Assessment Year: 2022
 Scenario: Background Demand

2008-2022 Factor
1.2448

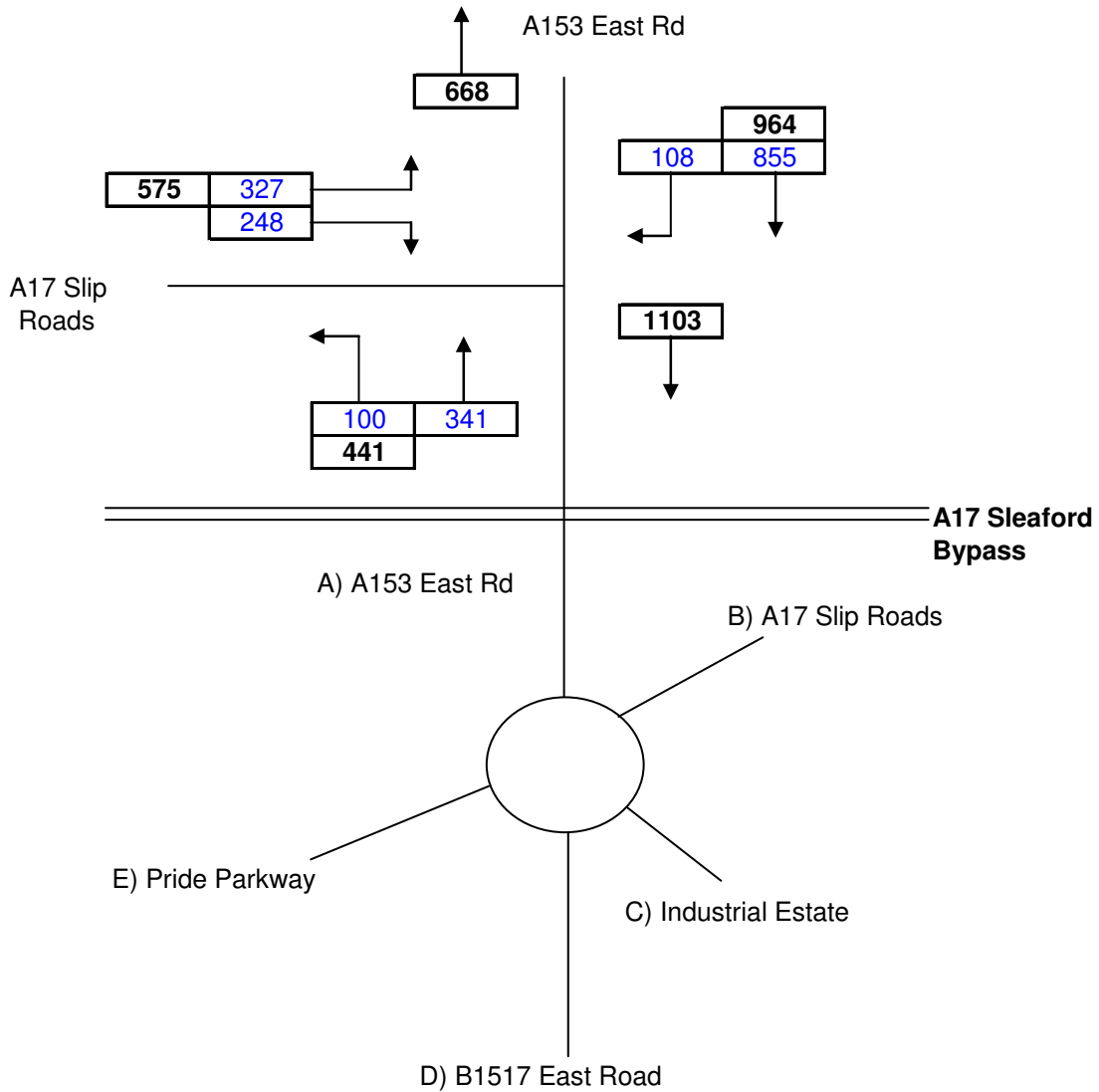

	A	B	C	D	E	Total
A		359	30	667	47	1103
B	108		10	169	32	320
C	2	1		4	0	7
D	302	76	4		61	443
E	27	26	1	20		75
Total	441	462	45	860	141	1948

Figure 10a

Predicted 2022 Future Year Traffic Flow Demand at Bone Mills Junctions
 AM Peak Period



Camellia House
 76 Water Lane,
 Wilmslow
 Cheshire, SK9 5BB

Eco 2

Sleaford RRP

March 2008

APB

552-01

Time Period: 12:00-13:00
 Assessment Year: 2022
 Scenario: Background Demand

2008-2022 Factor
1.2448

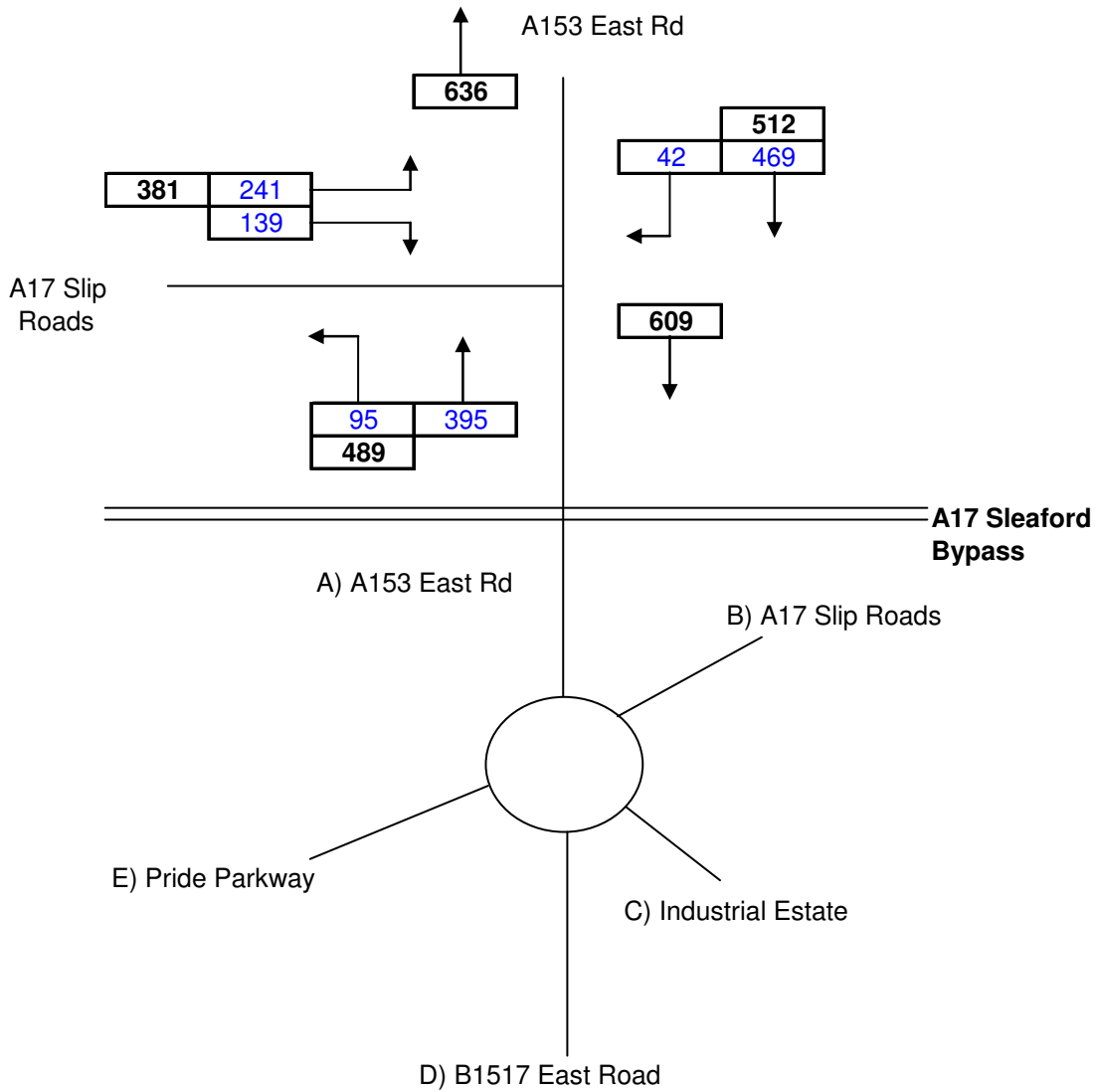

	A	B	C	D	E	Total
A		217	11	341	40	609
B	62		4	61	17	144
C	7	7		12	0	27
D	387	126	5		42	560
E	32	39	1	39		111
Total	489	388	21	453	100	1451

Figure 10b

Predicted 2022 Future Year Traffic Flow Demand at Bone Mills Junctions
 Lunchtime Peak Period



Camellia House
 76 Water Lane,
 Wilmslow
 Cheshire, SK9 5BB

Eco 2

Sleaford RRP

March 2008

APB

552-01

Time Period: 16:15-17:15
 Assessment Year: 2022
 Scenario: Background Demand

2008-2022 Factor
1.2448

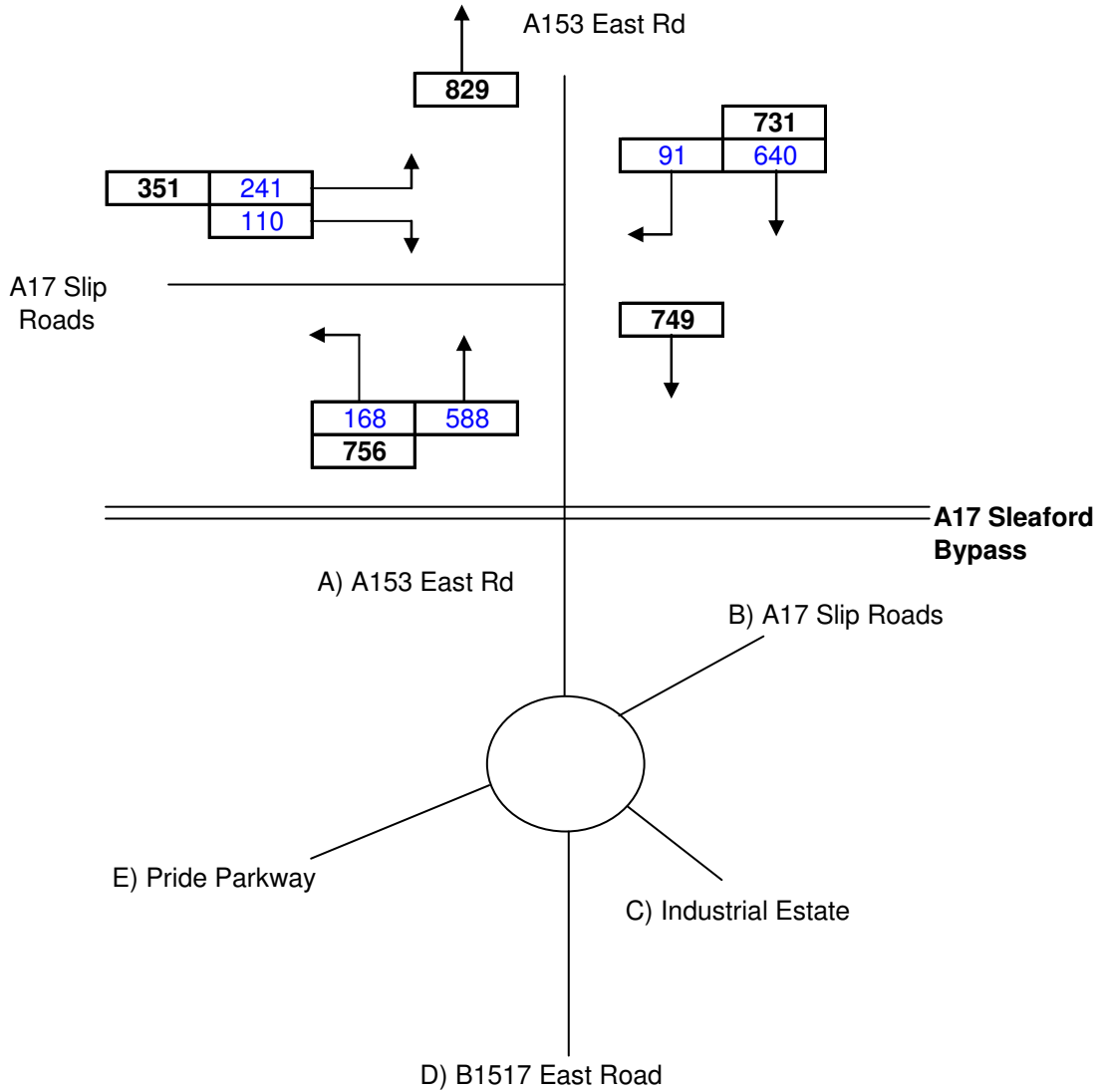

	A	B	C	D	E	Total
A		402	7	301	39	749
B	116		4	54	17	190
C	12	12		6	1	32
D	564	209	0		29	802
E	63	61	1	34		159
Total	756	685	12	395	86	1933

Figure 10c

Predicted 2022 Future Year Traffic Flow Demand at Bone Mills Junctions
 PM Peak Period



Camellia House
 76 Water Lane,
 Wilmslow
 Cheshire, SK9 5BB

Eco 2

Sleaford RRP

March 2008

APB

552-01

Time Period: 07:45-08:45
 Assessment Year: 2012
 Scenario: Opening Year Including Typical REP Demand

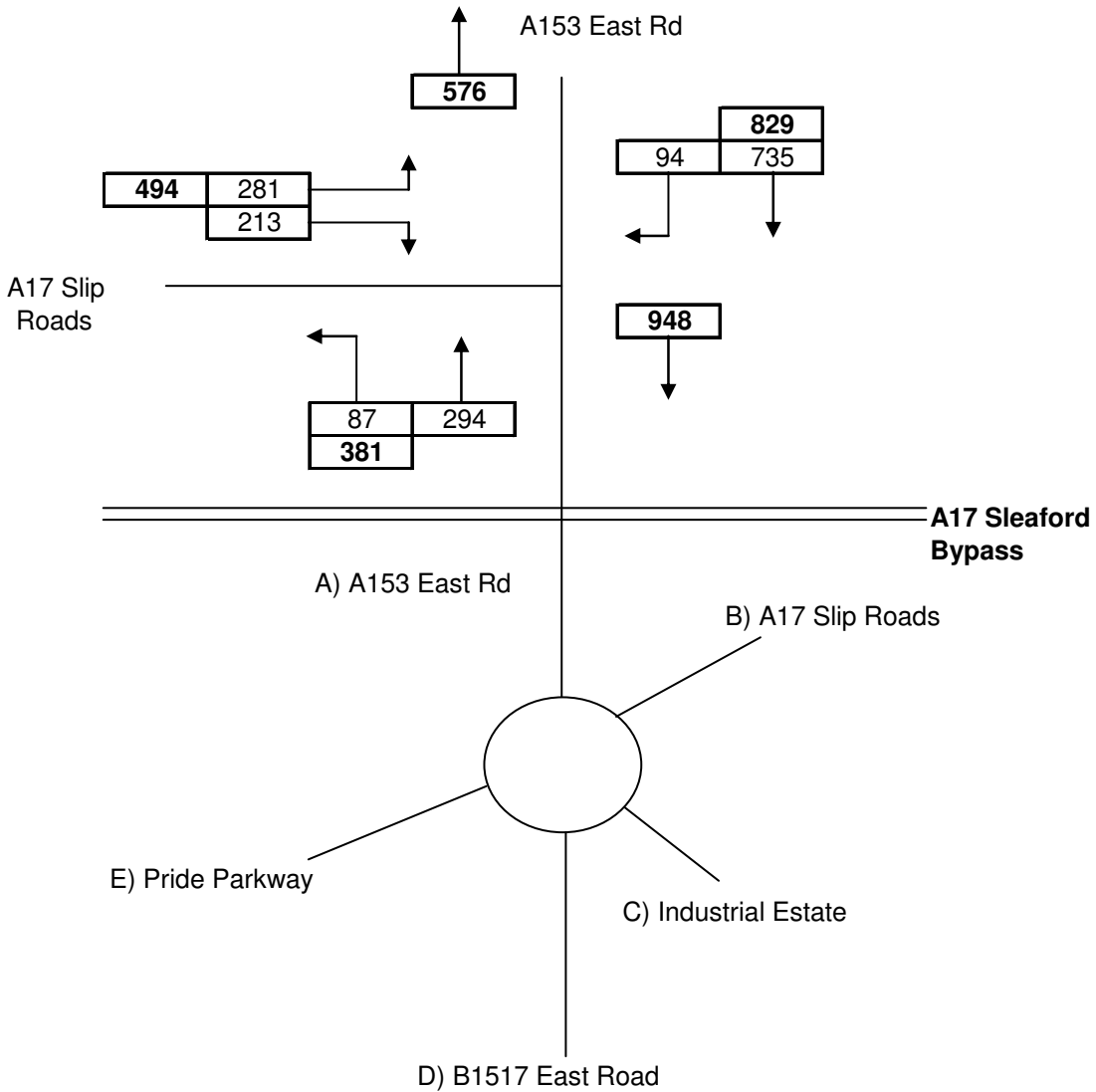

	A	B	C	D	E	Total
A		308	26	574	41	948
B	95		9	146	28	277
C	2	1		3	0	6
D	260	65	3		52	381
E	24	22	1	17		64
Total	381	397	39	739	121	1677

Figure 11a

Predicted 2012 Opening Year Traffic Flow Demand at Bone Mills Junctions
 Background + Development (TYPICAL): AM Peak Period



Camellia House
 76 Water Lane,
 Wilmslow
 Cheshire, SK9 5BB

Eco 2

Sleaford RRP

March 2008

APB

552-01

Time Period: 12:00-13:00
 Assessment Year: 2012
 Scenario: Opening Year Including Typical REP Demand

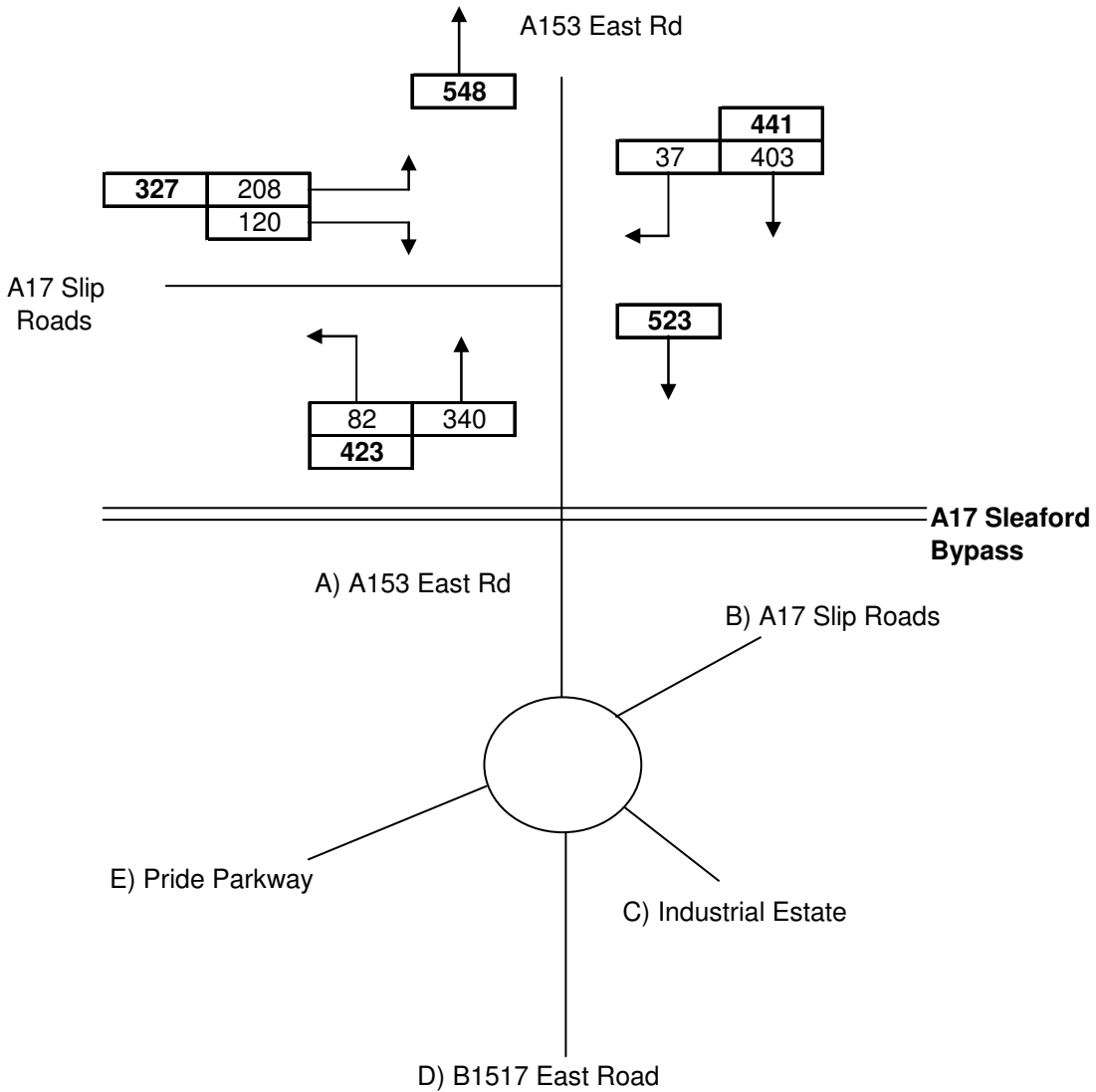

	A	B	C	D	E	Total
A		186	10	293	34	523
B	56		3	52	15	126
C	6	6		11	0	24
D	333	108	4		36	482
E	28	33	1	33		95
Total	423	334	18	389	86	1250

Figure 11b

Predicted 2012 Opening Year Traffic Flow Demand at Bone Mills Junctions
 Background + Development (TYPICAL): Lunchtime Peak Period



Camellia House
 76 Water Lane,
 Wilmslow
 Cheshire, SK9 5BB

Eco 2

Sleaford RRP

March 2008

APB

552-01

Time Period: 16:15-17:15
 Assessment Year: 2012
 Scenario: Opening Year Including Typical REP Demand

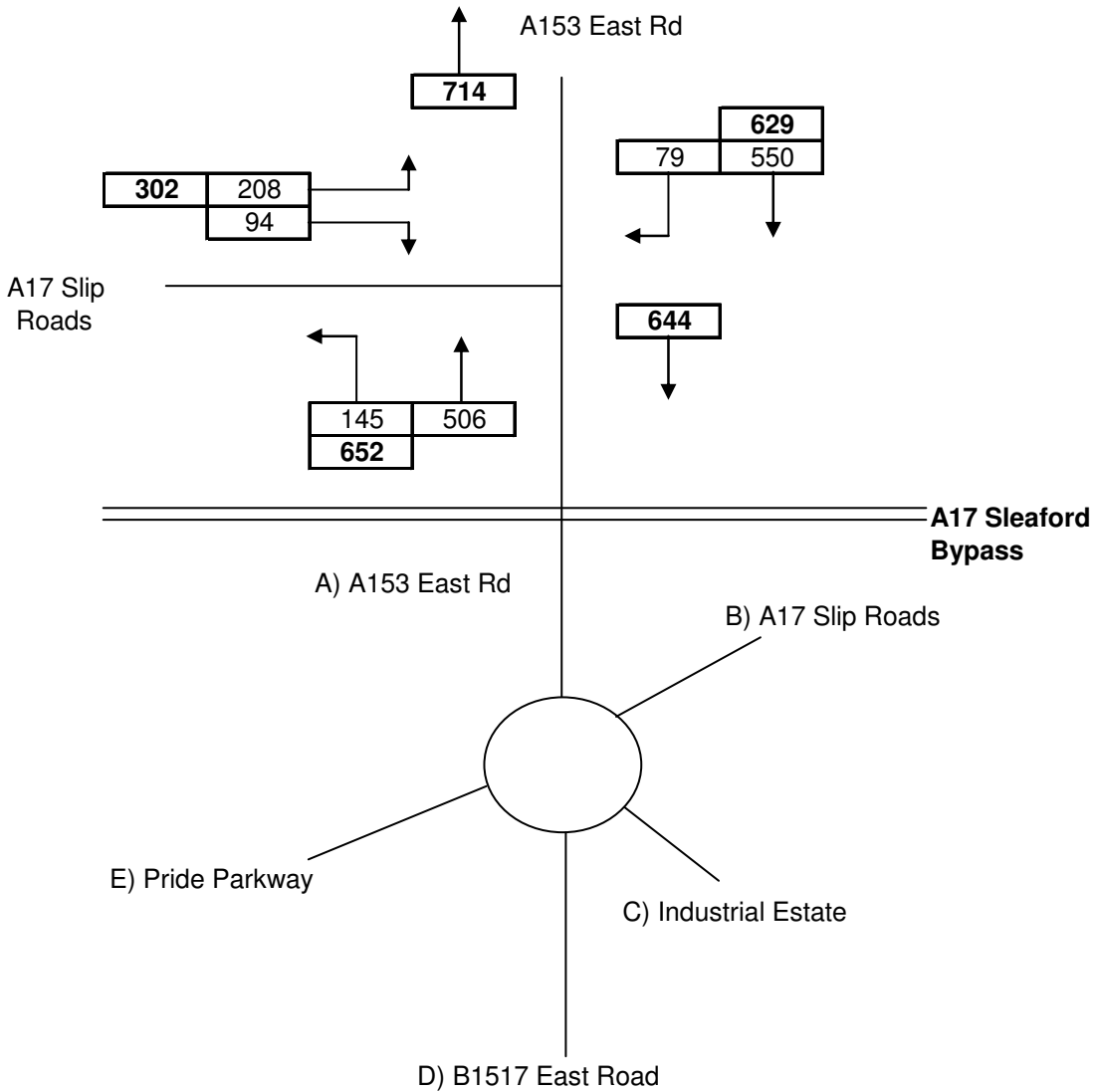

	A	B	C	D	E	Total
A		346	6	259	33	644
B	102		3	46	15	166
C	11	11		5	1	28
D	485	180	0		25	689
E	55	52	1	29		137
Total	652	589	11	339	74	1664

Figure 11c

Predicted 2012 Opening Year Traffic Flow Demand at Bone Mills Junctions
 Background + Development (TYPICAL): PM Peak Period



Camellia House
 76 Water Lane,
 Wilmslow
 Cheshire, SK9 5BB

Eco 2

Sleaford RRP

March 2008

APB

552-01

Time Period: 07:45-08:45
 Assessment Year: 2012
 Scenario: Opening Year Including Sensitivity REP Demand

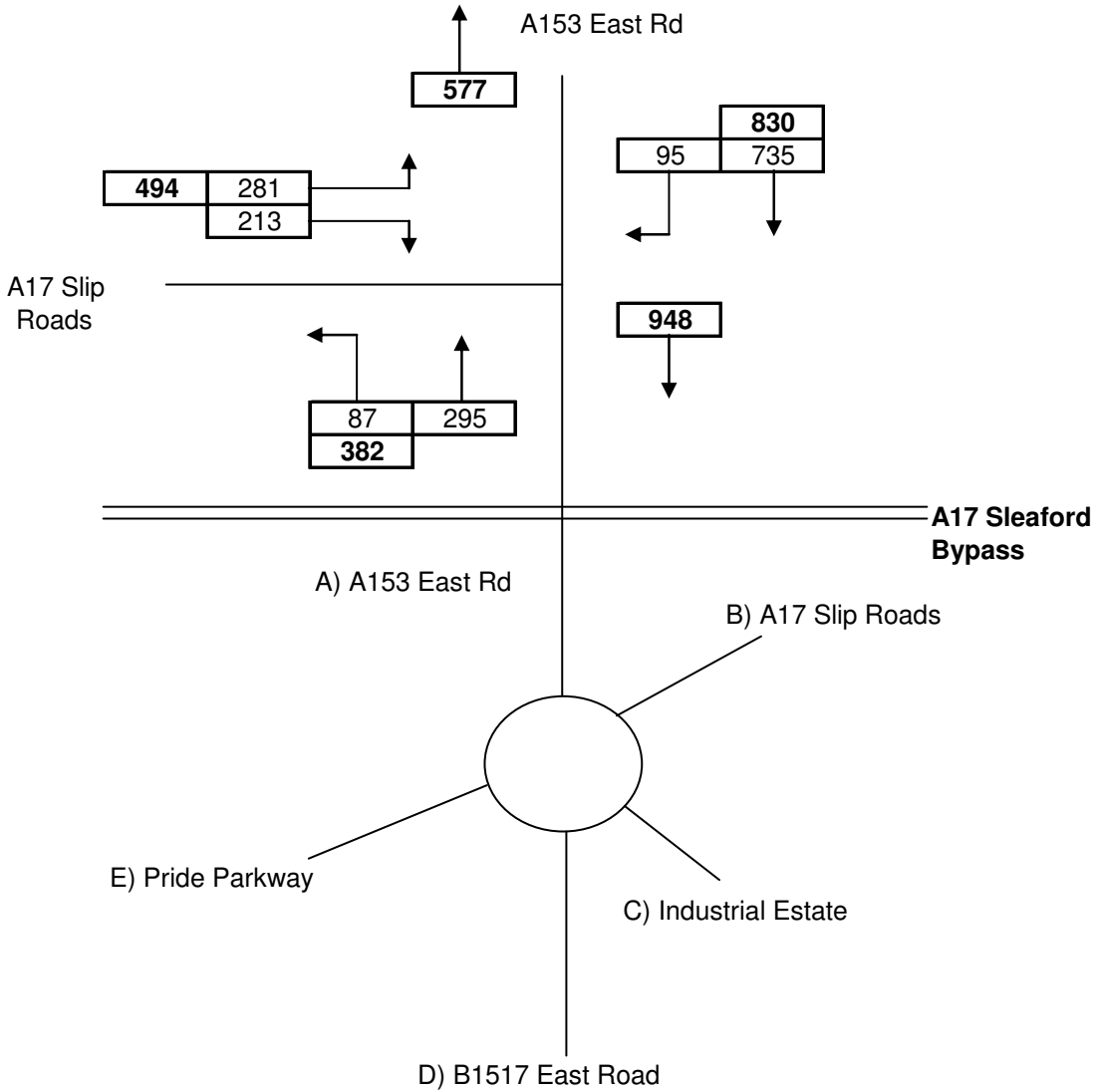

	A	B	C	D	E	Total
A		308	26	574	41	948
B	96		9	146	28	278
C	2	1		3	0	6
D	260	65	3		52	381
E	24	22	1	17		64
Total	382	397	39	739	121	1678

Figure 12a

Predicted 2012 Opening Year Traffic Flow Demand at Bone Mills Junctions
 Background + Development (SENSITIVITY): AM Peak Period



Camellia House
 76 Water Lane,
 Wilmslow
 Cheshire, SK9 5BB

Eco 2

Sleaford RRP

March 2008

APB

552-01

Time Period: 12:00-13:00
 Assessment Year: 2012
 Scenario: Opening Year Including Sensitivity REP Demand

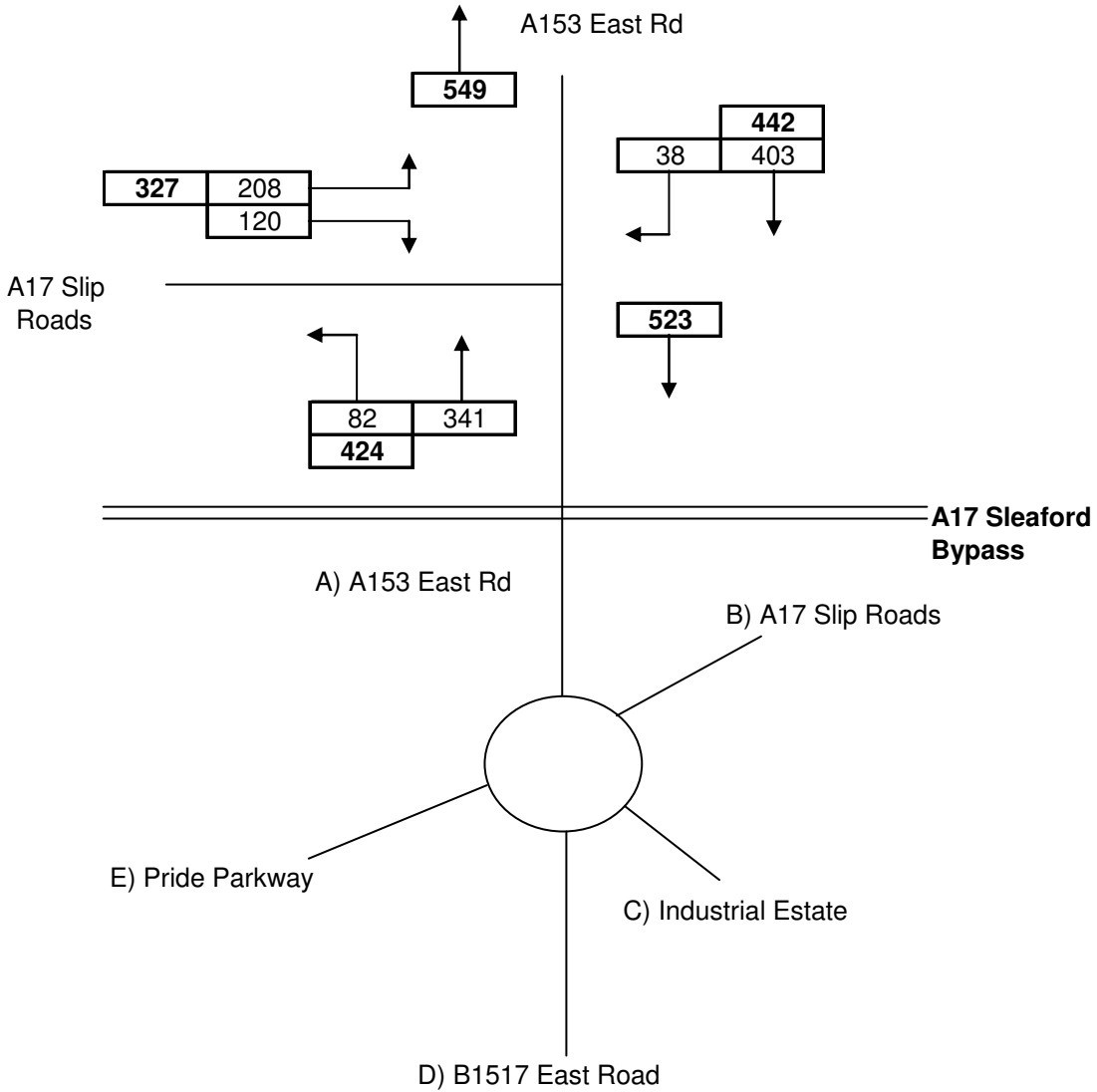

	A	B	C	D	E	Total
A		186	10	293	34	523
B	57		3	52	15	127
C	6	6		11	0	24
D	333	108	4		36	482
E	28	33	1	33		95
Total	424	334	18	389	86	1251

Figure 12b

Predicted 2012 Opening Year Traffic Flow Demand at Bone Mills Junctions
 Background + Development (SENSITIVITY): Lunchtime Peak Period



Camellia House
 76 Water Lane,
 Wilmslow
 Cheshire, SK9 5BB

Eco 2

Sleaford RRP

March 2008

APB

552-01

Time Period: 16:15-17:15
 Assessment Year: 2012
 Scenario: Opening Year Including Sensitivity REP Demand

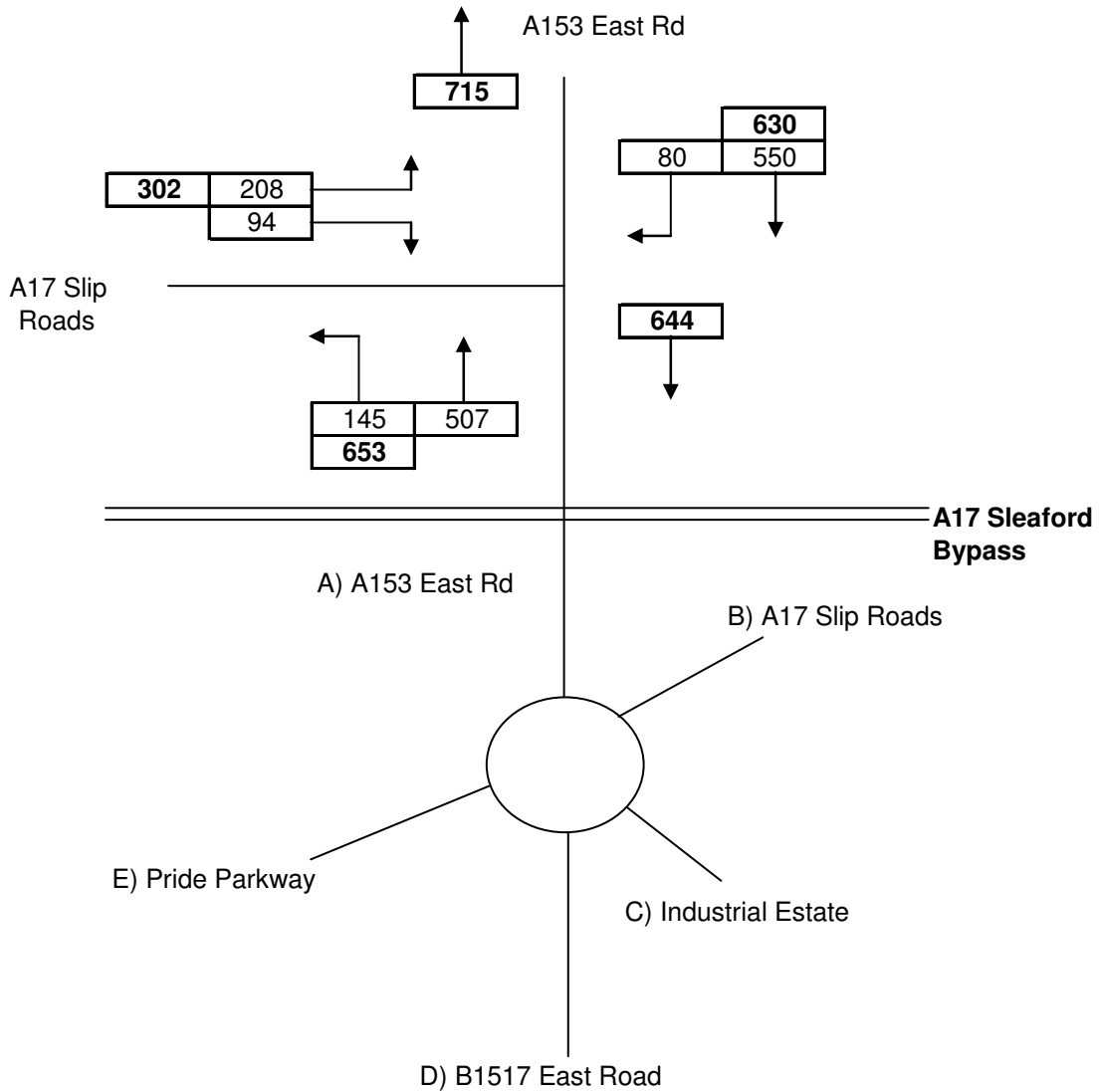

	A	B	C	D	E	Total
A		346	6	259	33	644
B	103		3	46	15	167
C	11	11		5	1	28
D	485	180	0		25	689
E	55	52	1	29		137
Total	653	589	11	339	74	1665

Figure 12c

Predicted 2012 Opening Year Traffic Flow Demand at Bone Mills Junctions
 Background + Development (SENSITIVITY): PM Peak Period



Camellia House
 76 Water Lane,
 Wilmslow
 Cheshire, SK9 5BB

Eco 2

Sleaford RRP

March 2008

APB

552-01

Time Period: 07:45-08:45
 Assessment Year: 2022
 Scenario: Future Year Including Typical REP Demand

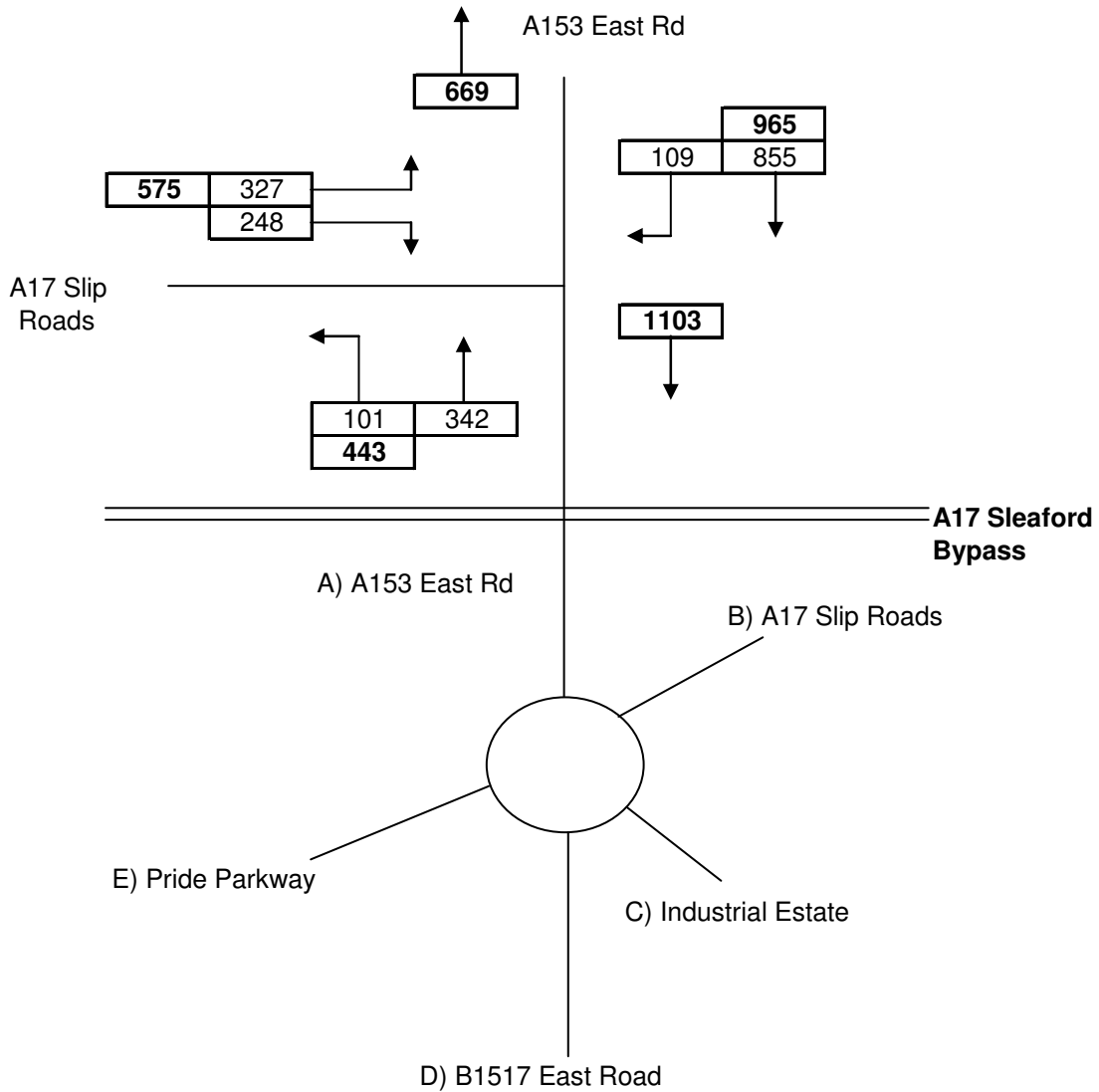

	A	B	C	D	E	Total
A		359	30	667	47	1103
B	110		10	169	32	322
C	2	1		4	0	7
D	302	76	4		61	443
E	27	26	1	20		75
Total	443	462	45	860	141	1950

Figure 13a

Predicted 2022 Future Year Traffic Flow Demand at Bone Mills Junctions
 Background + Development (TYPICAL): AM Peak Period



Camellia House
 76 Water Lane,
 Wilmslow
 Cheshire, SK9 5BB

Eco 2

Sleaford RRP

March 2008

APB

552-01

Time Period: 12:00-13:00
 Assessment Year: 2022
 Scenario: Future Year Including Typical REP Demand

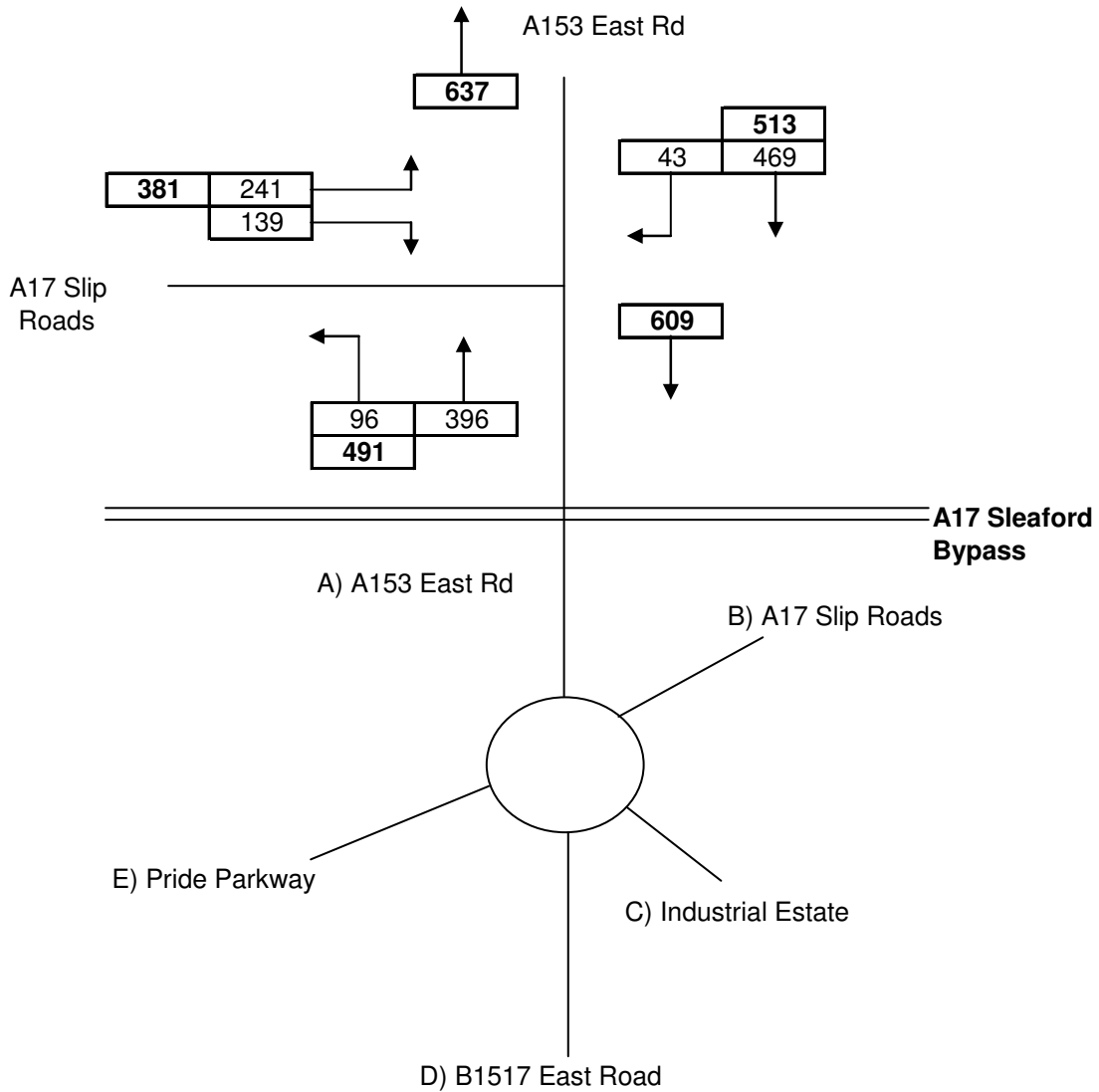

	A	B	C	D	E	Total
A		217	11	341	40	609
B	64		4	61	17	146
C	7	7		12	0	27
D	387	126	5		42	560
E	32	39	1	39		111
Total	491	388	21	453	100	1453

Figure 13b

Predicted 2022 Future Year Traffic Flow Demand at Bone Mills Junctions
 Background + Development (TYPICAL): Lunchtime Peak Period



Camellia House
 76 Water Lane,
 Wilmslow
 Cheshire, SK9 5BB

Eco 2

Sleaford RRP

March 2008

APB

552-01

Time Period: 16:15-17:15
 Assessment Year: 2022
 Scenario: Future Year Including Typical REP Demand

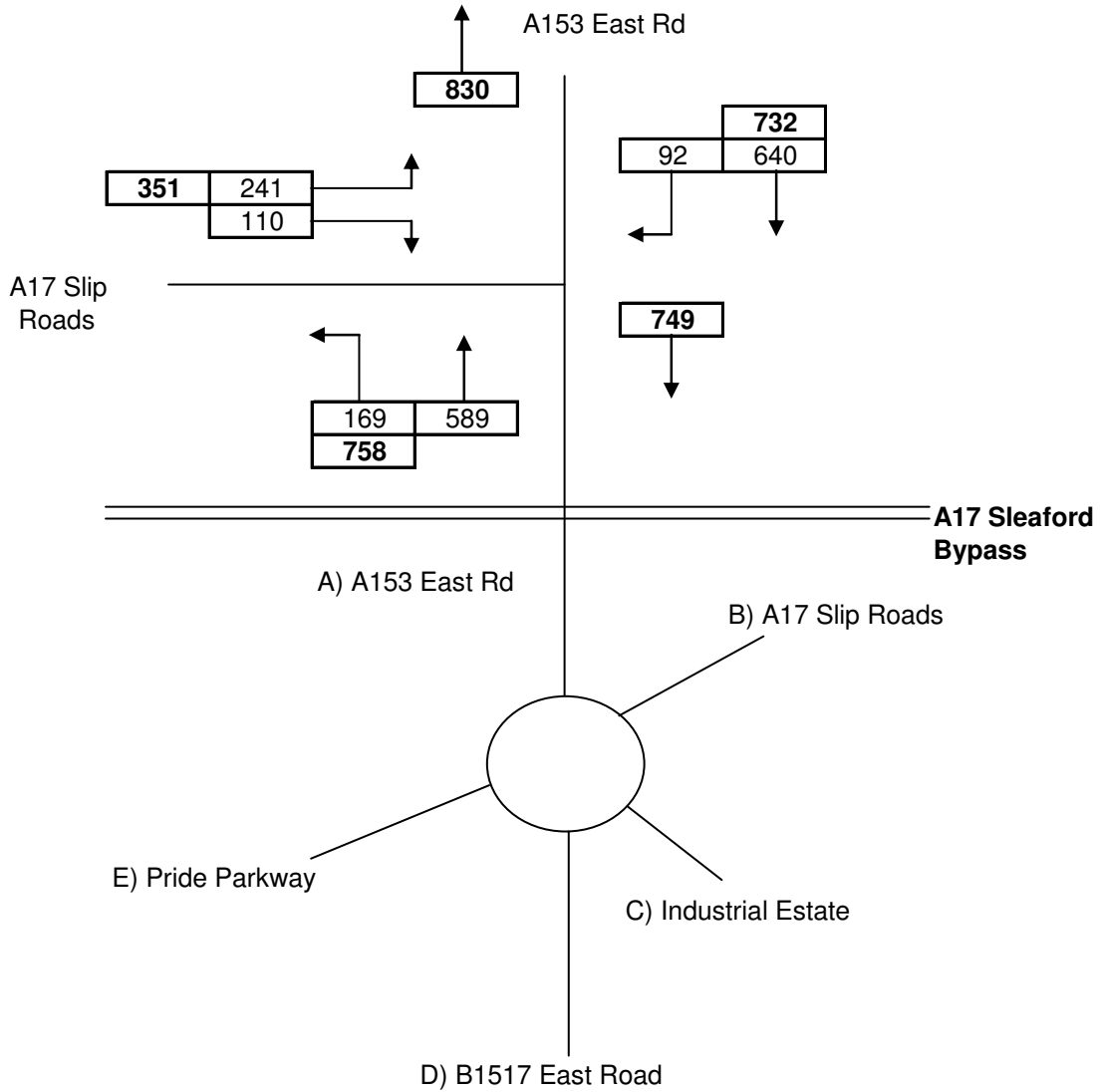

	A	B	C	D	E	Total
A		402	7	301	39	749
B	118		4	54	17	192
C	12	12		6	1	32
D	564	209	0		29	802
E	63	61	1	34		159
Total	758	685	12	395	86	1935

Figure 13c

Predicted 2022 Future Year Traffic Flow Demand at Bone Mills Junctions
 Background + Development (TYPICAL): PM Peak Period



Camellia House
 76 Water Lane,
 Wilmslow
 Cheshire, SK9 5BB

Eco 2

Sleaford RRP

March 2008

APB

552-01

Time Period: 07:45-08:45
 Assessment Year: 2022
 Scenario: Future Year Including Sensitivity REP Demand

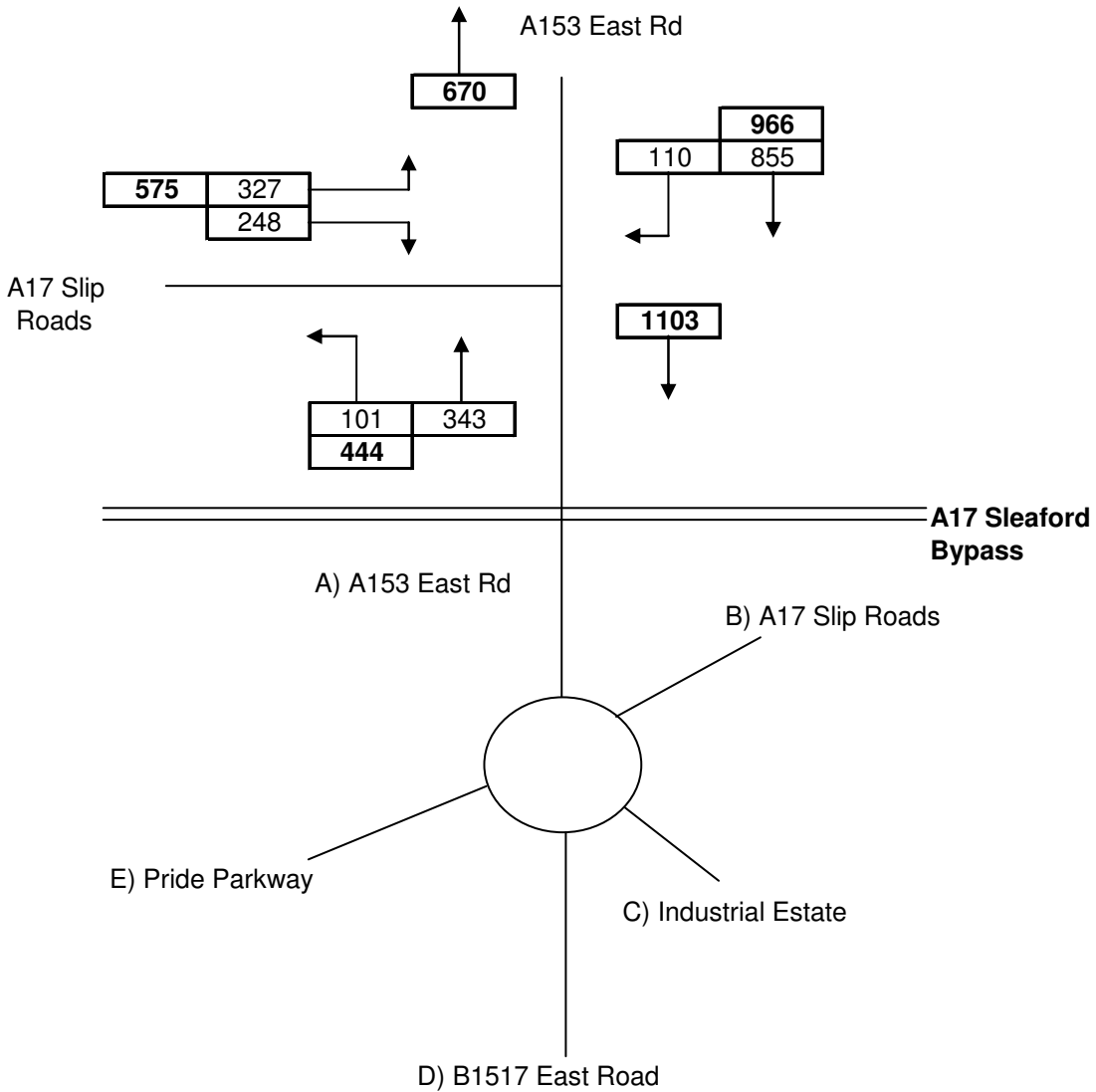

	A	B	C	D	E	Total
A		359	30	667	47	1103
B	111		10	169	32	323
C	2	1		4	0	7
D	302	76	4		61	443
E	27	26	1	20		75
Total	444	462	45	860	141	1951

Figure 14a

Predicted 2022 Future Year Traffic Flow Demand at Bone Mills Junctions
 Background + Development (SENSITIVITY): AM Peak Period



Camellia House
 76 Water Lane,
 Wilmslow
 Cheshire, SK9 5BB

Eco 2

Sleaford RRP

March 2008

APB

552-01

Time Period: 12:00-13:00
 Assessment Year: 2022
 Scenario: Future Year Including Sensitivity REP Demand

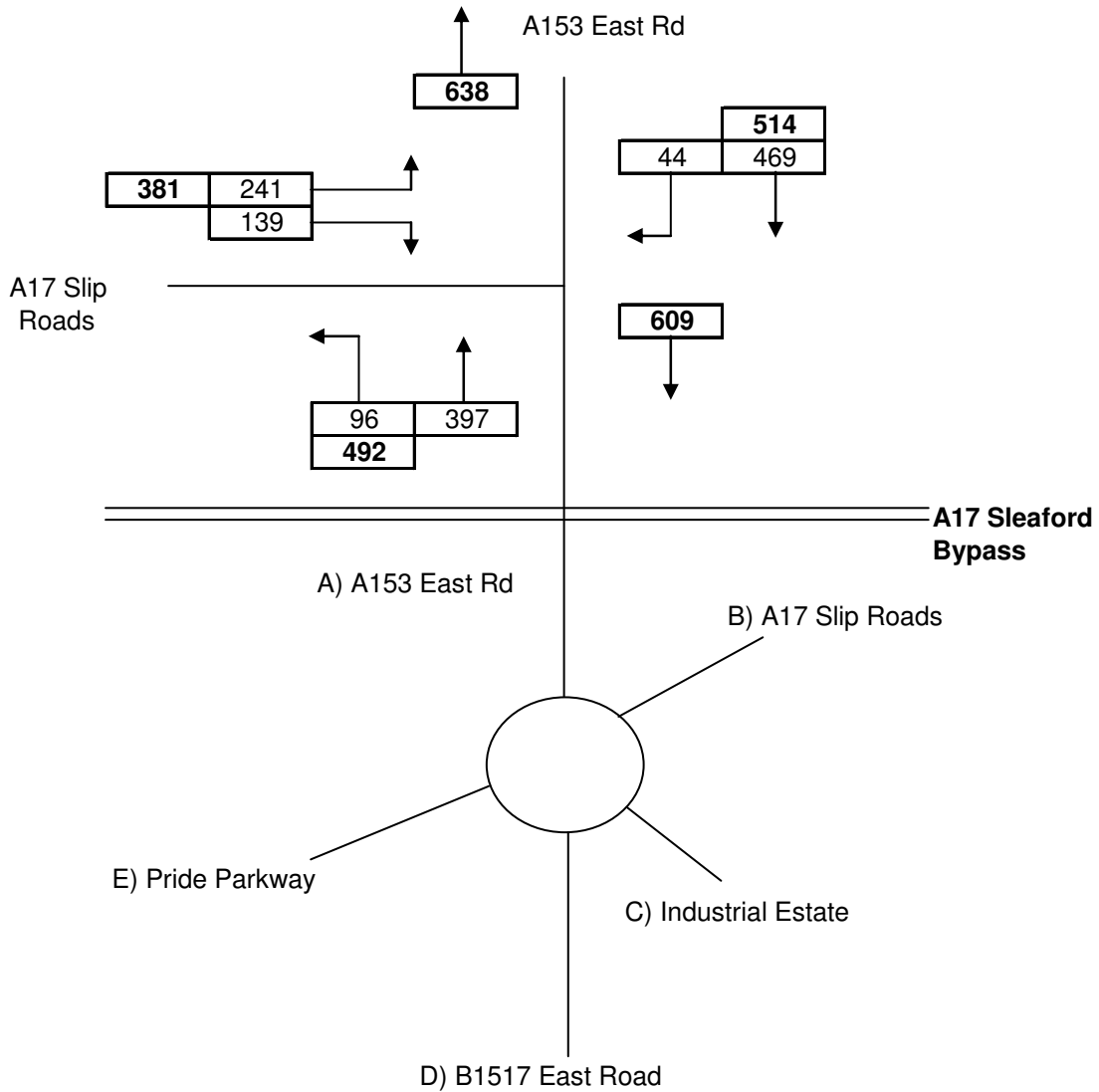

	A	B	C	D	E	Total
A		217	11	341	40	609
B	65		4	61	17	147
C	7	7		12	0	27
D	387	126	5		42	560
E	32	39	1	39		111
Total	492	388	21	453	100	1454

Figure 14b

Predicted 2022 Future Year Traffic Flow Demand at Bone Mills Junctions
 Background + Development (SENSITIVITY): Lunchtime Peak Period



Camellia House
 76 Water Lane,
 Wilmslow
 Cheshire, SK9 5BB

Eco 2

Sleaford RRP

March 2008

APB

552-01

Time Period: 16:15-17:15
 Assessment Year: 2022
 Scenario: Future Year Including Sensitivity REP Demand

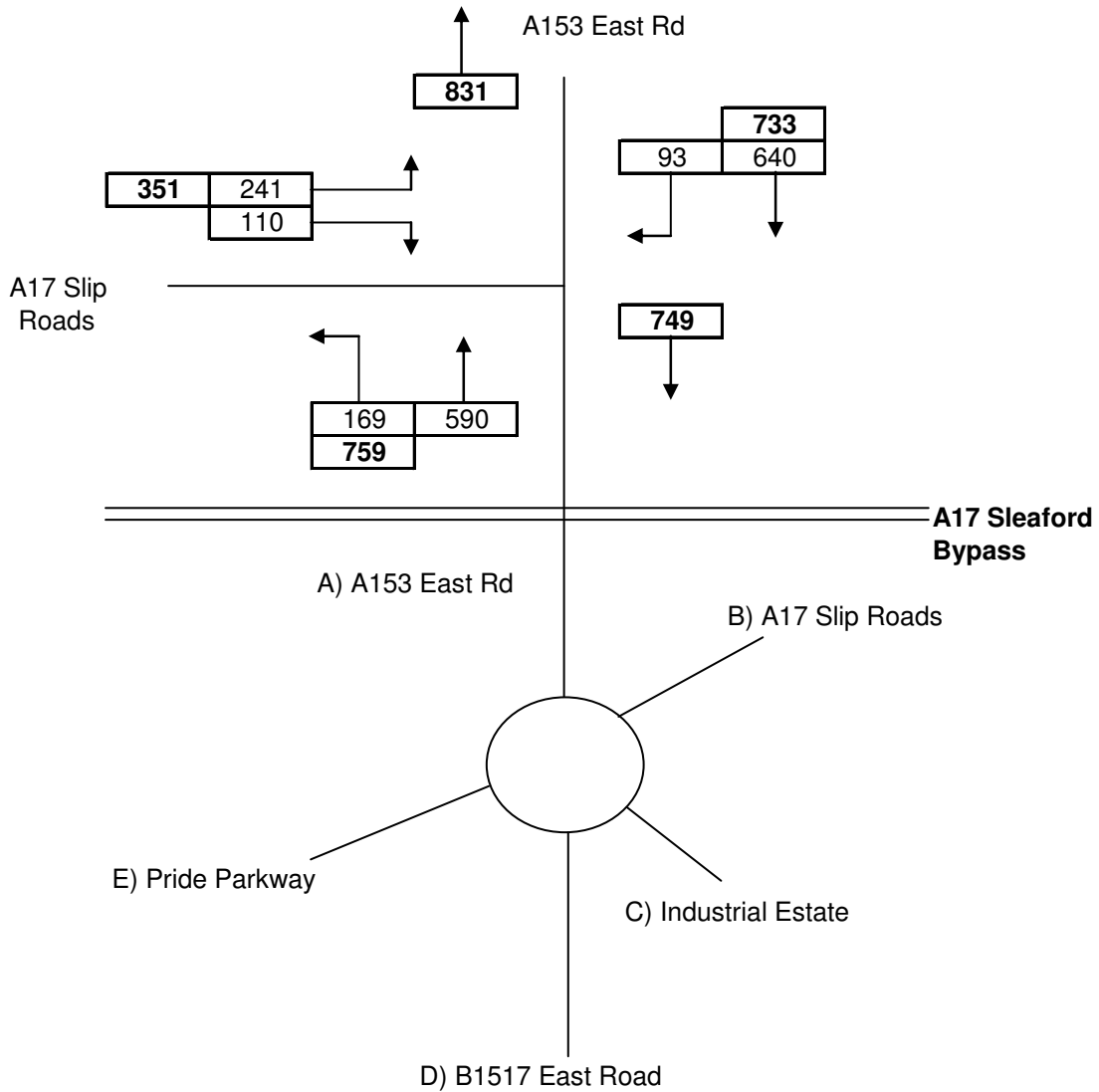

	A	B	C	D	E	Total
A		402	7	301	39	749
B	119		4	54	17	193
C	12	12		6	1	32
D	564	209	0		29	802
E	63	61	1	34		159
Total	759	685	12	395	86	1936

Figure 14c

Predicted 2022 Future Year Traffic Flow Demand at Bone Mills Junctions
 Background + Development (SENSITIVITY): PM Peak Period



Camellia House
 76 Water Lane,
 Wilmslow
 Cheshire, SK9 5BB

Eco 2

Sleaford RRP

March 2008

APB

552-01